

INCH-POUND
MIL-M-38510/190D
12 October 2005
SUPERSEDING
MIL-M-38510/190C
22 October 1986

MILITARY SPECIFICATION

MICROCIRCUITS, LINEAR, CMOS/ANALOG MULTIPLEXERS/DEMULTIPLEXERS WITH OVERVOLTAGE PROTECTION, MONOLITHIC SILICON, POSITIVE LOGIC

This specification is approved for use by all Departments and Agencies of the Department of Defense.

Inactive for new design as of 10 July 1995

The requirements for acquiring the product herein shall consist of this specification sheet and MIL-PRF-38535

1. SCOPE

1.1 Scope. This specification covers the detail requirements for monolithic silicon, CMOS/Analog logic microcircuits. Two product assurance classes and a choice of case outlines and lead finishes are provided and are reflected in the complete part number. For this product, the requirements of MIL-M-38510 have been superseded by MIL-PRF-38535, (see 6.4)

1.2 Part or Identifying Number (PIN). The PIN is in accordance with MIL-PRF-38535, and as specified herein.

1.2.1 Device types. The device types are as follows:

<u>Device type</u>	<u>Circuit</u>
01	Single 16-channel MUX/DEMUX
02	Single 16-channel MUX/DEMUX with overvoltage protection
03	Differential 8-channel MUX/DEMUX
04	Differential 8-channel MUX/DEMUX with overvoltage protection
05	Single 8-channel MUX/DEMUX with overvoltage protection
06	Differential 4-channel MUX/DEMUX with overvoltage protection
07	Single 8-channel MUX/DEMUX
08	Differential 4-channel MUX/DEMUX

1.2.2 Device class. The device class is the product assurance level as defined in MIL-PRF-38535.

1.2.3 Case outline. The case outlines are as designated in MIL-STD-1835 and as follows:

<u>Outline letter</u>	<u>Descriptive designator</u>	<u>Terminals</u>	<u>Package style</u>
E	GDIP1-T16 or CDIP2-T16	16	Dual-in-line
X	See figure 4	28	Dual-in-line

Comments, suggestions, or questions on this document should be addressed to: Commander, Defense Supply Center Columbus, ATTN: DSCC-VAS, 3990 East Broad St., Columbus, OH 43218-3990, or email <mailto:linear@dsc.dla.mil> . Since contact information can change, you may want to verify the currency of this address information using the ASSIST Online database at <http://assist.daps.dla.mil> .

1.3 Absolute maximum ratings.

Supply voltage between V+ and V-:	
Device types 02, 04, 05, and 06	+40 V
Device types 01, 03, 07, and 08	+32 V
V+ to ground:	
Device types 02, 04, 05, and 06	+20 V
Device types 01, 03, 07, and 08	+16 V
Digital input voltage:	
Device types 02, 04, 05, and 06	$((V-) - 4 \text{ V}) \leq V_D \leq ((V+) + 4 \text{ V})$
Device types 01, 03, 07, and 08	$-0.3 \text{ V} \leq V_D \leq (V+)$
Analog input:	
Device types 02, 04, 05, and 06	$((V-) - 20 \text{ V} \leq V_A \leq ((V+) + 20 \text{ V})$
Device types 01, 03, 07, and 08	$(V-) \leq V_A \leq (V+)$
Storage temperature	-65°C to +150°C
Lead temperature (soldering, 10 seconds)	300°C
Junction temperature (T _J).....	+175°C

1.4 Recommended operating conditions.

V+	+15 V
V-	-15 V
V _{REF}	Open
V _{IL} (max)	0.8 V
V _{IH} (min):	
Device types 01, 03, 07, and 08	2.4 V
Device types 02, 04, 05, and 06	4.0 V
V _{EN} :	
Device types 02, 04, 05, and 06	4.0 V
Device types 01, 03, 07, and 08	4.5 V
Ambient operating temperature range (T _A)	-55°C to +125°C

1.5 Power and thermal characteristics.

<u>Case outline</u>	<u>Maximum allowable power dissipation</u> <u>1/</u>	<u>Maximum</u> θ_{JC} <u>2/</u>	<u>Maximum</u> θ_{JA}
E	400 mW @ T _A = 125°C	50°C/W	125°C/W
X	400 mW @ T _A = 125°C	51°C/W	125°C/W

2. APPLICABLE DOCUMENTS

2.1 General. The documents listed in this section are specified in sections 3, 4, or 5 of this specification. This section does not include documents cited in other sections of this specification or recommended for additional information or as examples. While every effort has been made to ensure the completeness of this list, document users are cautioned that they must meet all specified requirements of documents cited in sections 3, 4, or 5 of this specification, whether or not they are listed.

1/ All leads welded or soldered to PC board.

2/ Applies only when T_A ≥ 75°C.

2.2 Government documents.

2.2.1 Specifications and Standards. The following specifications and standards form a part of this specification to the extent specified herein. Unless otherwise specified, the issues of these documents are those cited in the solicitation or contract.

DEPARTMENT OF DEFENSE SPECIFICATIONS

MIL-PRF-38535 - Integrated Circuits (Microcircuits) Manufacturing, General Specification for.

DEPARTMENT OF DEFENSE STANDARDS

MIL-STD-883 - Test Method Standard for Microelectronics.

MIL-STD-1835 - Interface Standard Electronic Component Case Outlines.

(Copies of these documents are available online at <http://assist.daps.dla.mil/quicksearch/> or <http://assist.daps.dla.mil> or from the Standardization Document Order Desk, 700 Robbins Avenue, Building 4D, Philadelphia, PA 19111-5094.

2.3 Order of precedence. In the event of a conflict between the text of this document and the references cited herein, the text of this document takes precedence. Nothing in this document, however, supersedes applicable laws and regulations unless a specific exemption has been obtained.

3. REQUIREMENTS

3.1 Qualification. Microcircuits furnished under this specification shall be products that are manufactured by a manufacturer authorized by the qualifying activity for listing on the applicable qualified manufacturers list before contract award (see 4.3 and 6.3).

3.2 Item requirements. The individual item requirements shall be in accordance with MIL-PRF-38535 and as specified herein or as modified in the device manufacturer's Quality Management (QM) plan. The modification in the QM plan shall not affect the form, fit, or function as described herein.

3.3 Design, construction, and physical dimensions. The design, construction, and physical dimensions shall be as specified in MIL-PRF-38535 and herein. Although eutectic die bonding is preferred, epoxy die bonding may be performed. However, the resin used shall be Dupont 5504A conductive silver paste, or equivalent, which is cured at 200°C ±10°C for a minimum of 2 hours. The use of equivalent epoxies or cure cycles shall be approved by the qualifying activity. Equivalency shall be demonstrated in data submitted to the qualifying activity for verification.

3.3.1 Terminal connections. The terminal connections shall be as specified on figure 1.

3.3.2 Functional diagrams. The functional diagrams shall be as specified on figure 2.

3.3.3 Truth tables. The truth tables shall be as specified on figure 3.

3.3.4 Case outline. The case outline shall be as specified in 1.2.3 and figure 4.

3.3.5 Schematic circuits. The schematic circuits shall be maintained by the manufacturer and made available to the qualifying activity and the preparing activity (DSCC-VA) upon request.

3.4 Lead material and finish. The lead material and finish shall be in accordance with MIL-PRF-38535 (see 6.6).

3.5 Electrical performance characteristics. The electrical performance characteristics are as specified in table I, and apply over the full recommended ambient operating temperature range, unless otherwise specified.

3.6 Electrical test requirements. Electrical test requirements for each device class shall be the subgroups specified in table II. The electrical tests for each subgroup are described in table III.

3.7 Marking. Marking shall be in accordance with MIL-PRF-38535.

3.8 Microcircuit group assignment. The devices covered by this specification shall be in microcircuit group number 82 (see MIL-PRF-38535, appendix A).

TABLE I. Electrical performance characteristics.

Test	Symbol	Conditions <u>1/</u> <u>2/</u> V- = -15 V, V+ = +15 V, V _{EN} = 4.5 V, GND = 0 V, -55°C ≤ T _A ≤ +125°C unless otherwise specified	Device type	Limits		Unit
				Min	Max	
Positive input clamping voltage	V _{IC(POS)}	T _A = 25°C, V+ = V- = 0 V, I _{IN} = 1 mA	02, 04, 05, 06		1.5	V dc
Negative input clamping voltage	V _{IC(NEG)}	T _A = 25°C, V+ = V- = 0 V, I _{IN} = -1 mA	02, 04, 05, 06	-1.5		V dc
Input leakage current <u>3/</u>	I _{IH}	Measure address inputs sequentially, connect all unused address inputs to GND	All	-0.1	+1.0	μA
Input leakage current <u>3/</u>	I _{IL}	Measure address inputs sequentially, connect all unused address inputs to 5 V	All	-1.0	+0.1	μA
Leakage current into the source terminal of an "OFF" switch	I _{S(OFF)}	V _S = 10 V, V _{EN} = 0.8 V, All unused sources = -10 V, T _A = 25°C	All	-1	1	nA
		V _S = 10 V, V _{EN} = 0.8 V, All unused sources = -10 V, -55°C ≤ T _A ≤ 125°C		-50	50	
		V _S = -10 V, V _{EN} = 0.8 V, All unused sources = +10 V, T _A = 25°C		-1	1	
		V _S = -10 V, V _{EN} = 0.8 V, All unused sources = +10 V, -55°C ≤ T _A ≤ 125°C		-50	50	
Leakage current into the drain terminal of an "OFF" switch	I _{D(OFF)}	V _D = 10 V, V _{EN} = 0.8 V, All unused sources = -10 V, T _A = 25°C	01, 02	-20	20	nA
			03, 04, 05, 06, 07, 08	-10	10	
		V _D = 10 V, V _{EN} = 0.8 V, All unused sources = -10 V, -55°C ≤ T _A ≤ 125°C	01, 02	-500	500	
			03, 04, 05, 07	-250	250	
			06, 08	-125	125	

See footnotes at end of table.

TABLE I. Electrical performance characteristics – Continued.

Test	Symbol	Conditions <u>1/</u> <u>2/</u> V ₋ = -15 V, V ₊ = +15 V, V _{EN} = 4.5 V, GND = 0 V, -55°C ≤ T _A ≤ +125°C unless otherwise specified	Device type	Limits		Unit
				Min	Max	
Leakage current into the drain terminal of an “OFF” switch	I _{D(OFF)}	V _D = 10 V, V _{EN} = 0.8 V, All unused sources = -10 V, T _A = 25°C	01, 02	-20	20	nA
			03, 04, 05, 06, 07, 08	-10	10	
		V _D = 10 V, V _{EN} = 0.8 V, All unused sources = -10 V, -55°C ≤ T _A ≤ 125°C	01, 02	-500	500	
			03, 04, 05, 07	-250	250	
			06, 08	-125	125	
Leakage current from an “ON” driver into the switch (drain)	I _{D(ON)}	V _S = 10 V, V _D = 10 V, Connect all unused sources to -10 V, T _A = 25°C	01, 02	-20	20	nA
			03, 04, 05, 06, 07, 08	-10	10	
		V _S = 10 V, V _D = 10 V, Connect all unused sources to -10 V, -55°C ≤ T _A ≤ 125°C	01, 02	-500	500	
			03, 04, 05, 07	-250	250	
			06, 08	-125	125	
		V _S = 10 V, V _D = -10 V, Connect all unused sources to -10 V, T _A = 25°C	01, 02	-20	20	
			03, 04, 05, 06, 07, 08	-10	10	
		V _S = 10 V, V _D = -10 V, Connect all unused sources to -10 V, -55°C ≤ T _A ≤ 125°C	01, 02	-500	500	
			03, 04, 05, 07	-250	250	
			06, 08	-125	125	

See footnotes at end of table.

TABLE I. Electrical performance characteristics – Continued.

Test	Symbol	Conditions 1/ 2/ V ₋ = -15 V, V ₊ = +15 V, V _{EN} = 4.5 V, GND = 0 V, -55°C ≤ T _A ≤ +125°C unless otherwise specified	Device type	Limits		Unit
				Min	Max	
Overvoltage protected, leakage current into the drain terminal of an “OFF” switch	I _{D(OFF)} overvoltage	V _S = 33 V, V _D = 0 V, V _{EN} = 0.8 V	02, 04, 05, 06	-2.0	2.0	μA
		V _S = -33 V, V _D = 0 V, V _{EN} = 0.8 V		-2.0	2.0	
Positive supply current	I(+)	V _A = 0 V, V _{EN} = 5 V	01, 03		14	mA
			02, 04, 05, 06		2.0	
			07, 08		12	
Negative supply current	I(-)	V _A = 0 V, V _{EN} = 5 V	01, 03	-14		mA
			02, 04, 05, 06	-1		
			07, 08	-12		
Standby positive supply current	I+SBY	V _A = 0 V, V _{EN} = 0 V	01, 03		3.0	mA
			02, 04, 05, 06		2.0	
			07, 08		3.5	
Standby negative supply current	I-SBY	V _A = 0 V, V _{EN} = 0 V	01, 03	-4.0		mA
			02, 04, 05, 06	-1.0		
			07, 08	-3.5		
Capacitance: Address	C _A	V ₊ = V ₋ = 0 V, T _A = 25°C, f = 1 MHz	All		10	pF
Capacitance: Enable	C _{EN}	V ₊ = V ₋ = 0 V, T _A = 25°C, f = 1 MHz	All		10	pF
Capacitance: Output switch	C _{OS}	V ₊ = V ₋ = 0 V, See table III	01		90	pF
			02		85	
			03, 04		50	
			05, 07		45	
			06, 08		25	
Capacitance: Input switch	C _{IS}	V ₊ = V ₋ = 0 V, See table III	All		10	pF

See footnotes at end of table.

TABLE I. Electrical performance characteristics – Continued.

Test	Symbol	Conditions <u>1/</u> <u>2/</u> V ₋ = -15 V, V ₊ = +15 V, V _{EN} = 4.5 V, GND = 0 V, -55°C ≤ T _A ≤ +125°C unless otherwise specified	Device type	Limits		Unit
				Min	Max	
Switch "ON" resistance	R _{DS1}	V _S = 10 V, I _D = 1 mA, T _A = 25°C, T _A = -55°C	01, 03		600	Ω
					700	
		V _S = 10 V, I _D = 100 μA, T _A = 25°C, T _A = -55°C	02, 04		1,500	
					2,000	
		V _S = 10 V, I _D = 100 μA, T _A = 25°C, T _A = -55°C	05, 06		1,500	
					1,800	
		V _S = 10 V, I _D = 1 mA, T _A = 25°C, T _A = -55°C	07, 08		400	
					500	
V _S = 10 V, I _D = 1 mA, T _A = 125°C						
Switch "ON" resistance	R _{DS1}	V _S = -10 V, I _D = -1 mA, T _A = 25°C, T _A = -55°C	01, 03		600	Ω
					700	
		V _S = -10 V, I _D = -100 μA, T _A = 25°C, T _A = -55°C	02, 04		1,500	
					2,000	
		V _S = -10 V, I _D = -100 μA, T _A = 25°C, T _A = -55°C	05, 06		1,500	
					1,800	
		V _S = -10 V, I _D = -100 μA, T _A = 125°C	07, 08		400	
					500	
V _S = -10 V, I _D = -1 mA, T _A = 125°C						

See footnotes at end of table.

TABLE I. Electrical performance characteristics – Continued.

Test	Symbol	Conditions ^{1/} _{2/} V ₋ = -15 V, V ₊ = +15 V, V _{EN} = 4.5 V, GND = 0 V, -55°C ≤ T _A ≤ +125°C unless otherwise specified	Device type	Limits		Unit
				Min	Max	
Switch “ON” resistance	R _{DS2}	V ₊ = 10 V, V ₋ = -10 V, V _S = 7.5 V, I _D = 1 mA	01, 03, 07, 08		1,000	Ω
		V ₊ = 10 V, V ₋ = -10 V, V _S = 7.5 V, I _D = 100 μA	02, 04		2,400	
			05, 06		2,200	
		V ₊ = 10 V, V ₋ = -10 V, V _S = -7.5 V, I _D = -1 mA	01, 03, 07, 08		1,000	
		V ₊ = 10 V, V ₋ = -10 V, V _S = -7.5 V, I _D = -100 μA	02, 04		2,400	
		05, 06		2,200		
Single channel isolation	V _{ISO}	f = 200 kHz, V _{GEN} = 1 V _{P-P} , see figure 15	All	50		dB
Crosstalk between channels	V _{CT}	F = 200 kHz, V _{GEN} = 1 V _{P-P} , see figure 16	All	50		dB
Charge transfer error	V _{CTE}	V _S = GND, see figure 17	All		10	mV
Break-before-make time delay	t _D	See figure 14, T _A = 25°C	All	5		ns
Propagation delay times: Address inputs to I/O channels	t _{ON(A)} t _{OFF(A)}	R _L = 1 kΩ, C _L = 100 pF, see figures 6, 8, 10, and 12, T _A = 25°C, T _A = -55°C	All		1,000	ns
		R _L = 1 kΩ, C _L = 100 pF, see figures 6, 8, 10, and 12, T _A = 125°C			1,500	
Enable to I/O	t _{ON(EN)} t _{OFF(EN)}	R _L = 1 kΩ, C _L = 100 pF, see figures 7, 9, 11, and 13, T _A = 25°C, T _A = -55°C	All		1,000	ns
		R _L = 1 kΩ, C _L = 100 pF, see figures 7, 9, 11, and 13, T _A = 125°C			1,500	

^{1/} Current flowing in either direction between any associated input and output terminals of the switch shall be 30 mA maximum.

^{2/} Input = source; Output = drain.

^{3/} Input current of one input node.

4. VERIFICATION.

4.1 Sampling and inspection. Sampling and inspection procedures shall be in accordance with MIL-PRF-38535 or as modified in the device manufacturer's Quality Management (QM) plan. The modification in the QM plan shall not affect the form, fit, or function as function as described herein.

4.2 Screening. Screening shall be in accordance with MIL-PRF-38535, and shall be conducted on all devices prior to qualification and quality conformance inspection. The following additional criteria shall apply:

- a. The burn-in test duration, test condition, and test temperature, or approved alternatives shall be as specified in the device manufacturer's QM plan in accordance with MIL-PRF-38535. The burn-in test circuit shall be maintained under document control by the device manufacturer's Technology Review Board (TRB) in accordance with MIL-PRF-38535 and shall be made available to the acquiring or preparing activity upon request. The test circuit shall specify the inputs, outputs, biases, and power dissipation, as applicable, in accordance with the intent specified in test method 1015 of MIL-STD-883.
- b. Interim and final electrical test parameters shall be as specified in table II, except interim electrical parameters test prior to burn-in is optional at the discretion of the manufacturer.
- c. Additional screening for space level product shall be as specified in MIL-PRF-38535.

4.3 Qualification inspection. Qualification inspection shall be in accordance with MIL-PRF-38535.

4.4 Technology Conformance inspection (TCI). Technology conformance inspection shall be in accordance with MIL-PRF-38535 and herein for groups A, B, C, and D inspections (see 4.4.1 through 4.4.4).

TABLE II. Electrical test requirements.

MIL-PRF-38535 test requirements	Subgroups (see table III)	
	Class S devices <u>4/</u>	Class B devices
Interim electrical parameters	1	1
Final electrical test parameters	1, 2, 3, 9	1, 2, 3,9
Group A test requirements	1,2,3,4,9,10, 11,12,13	1,2,3,4,9,12,13
Group B electrical test parameters when using the method 5005 QCI option	1,2,3 and table IV delta limits	N/A
Group C end-point electrical parameters	1,2,3 and table IV delta limits	1 and table IV delta limits
Additional electrical subgroups for group C periodic inspections	N/A	10, 11, 12
Group D end-point electrical parameters	1,2,3	1
Additional electrical subgroups for group D periodic inspection	12	None

1/ PDA applies to subgroup 1.

2/ See 4.4.1c

3/ See 4.4.1e

4/ See 4.4.4b

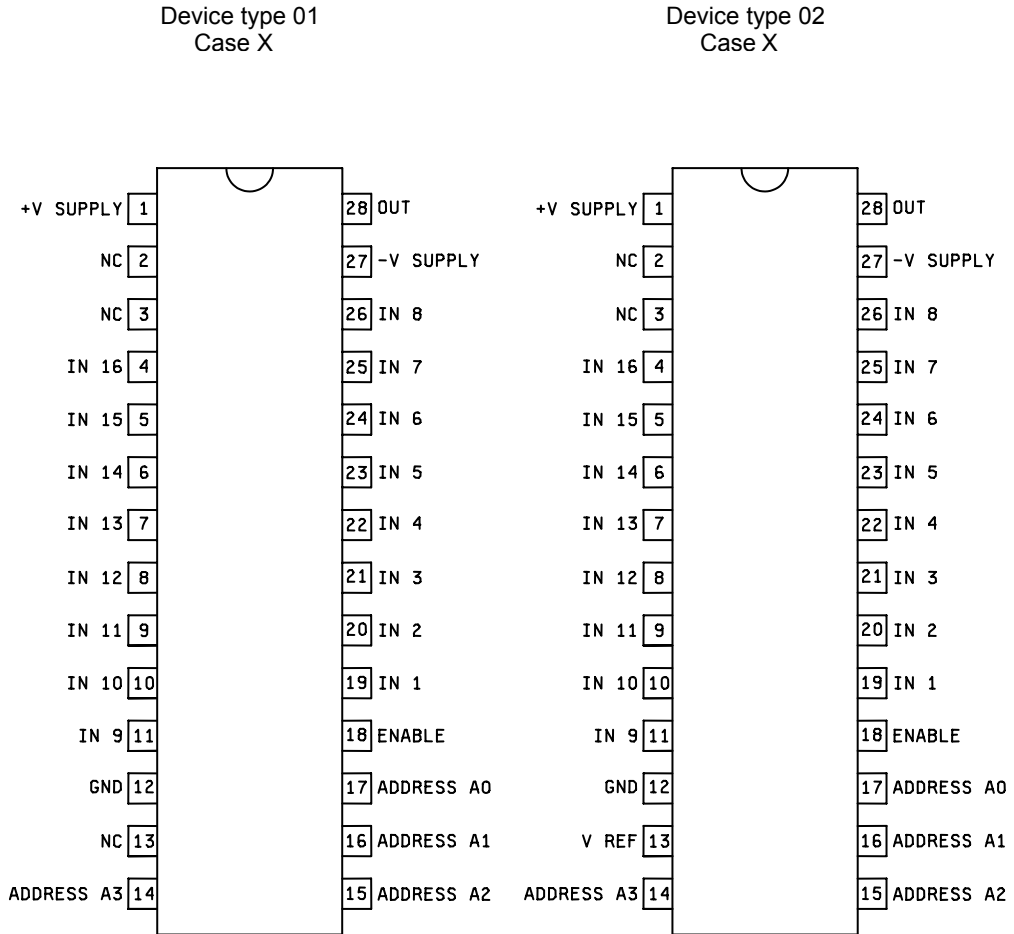

Figure 1. Terminal connections.

Device type 03
Case X

Device type 04
Case X

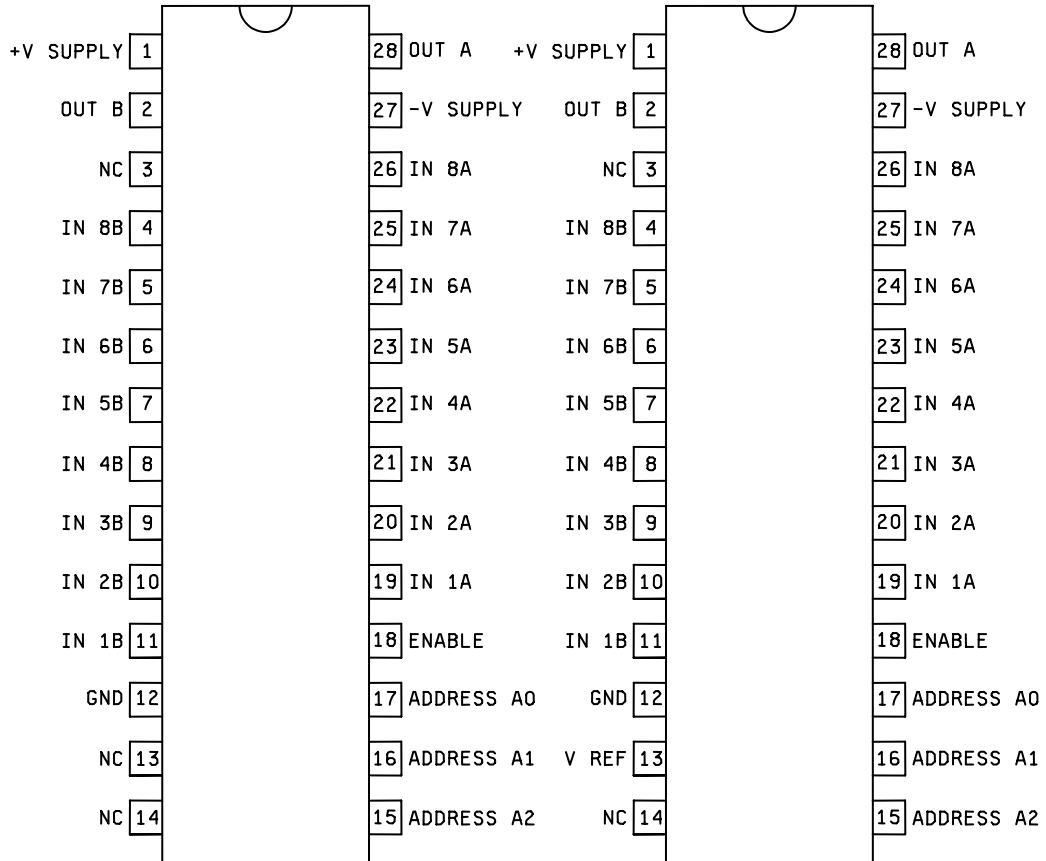
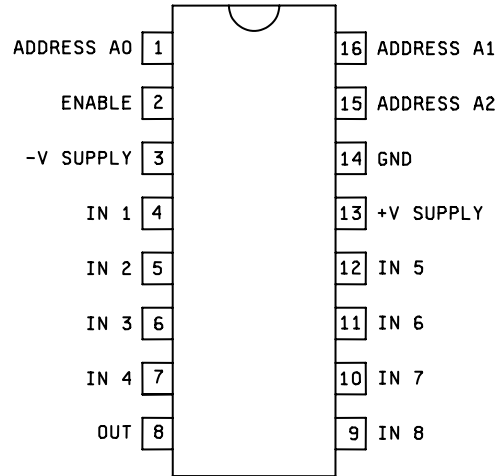

Figure 1. Terminal connections – Continued.

Device types 05 and 07
Case E



Device types 06 and 08
Case E

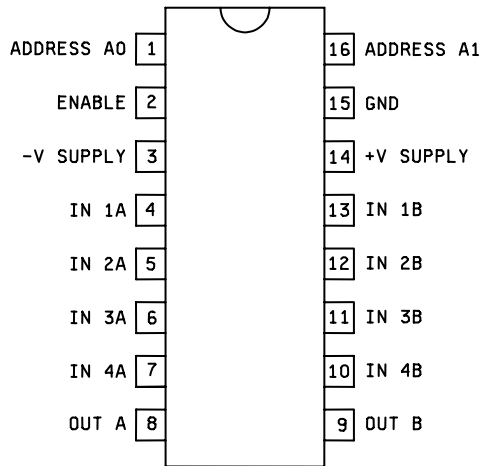
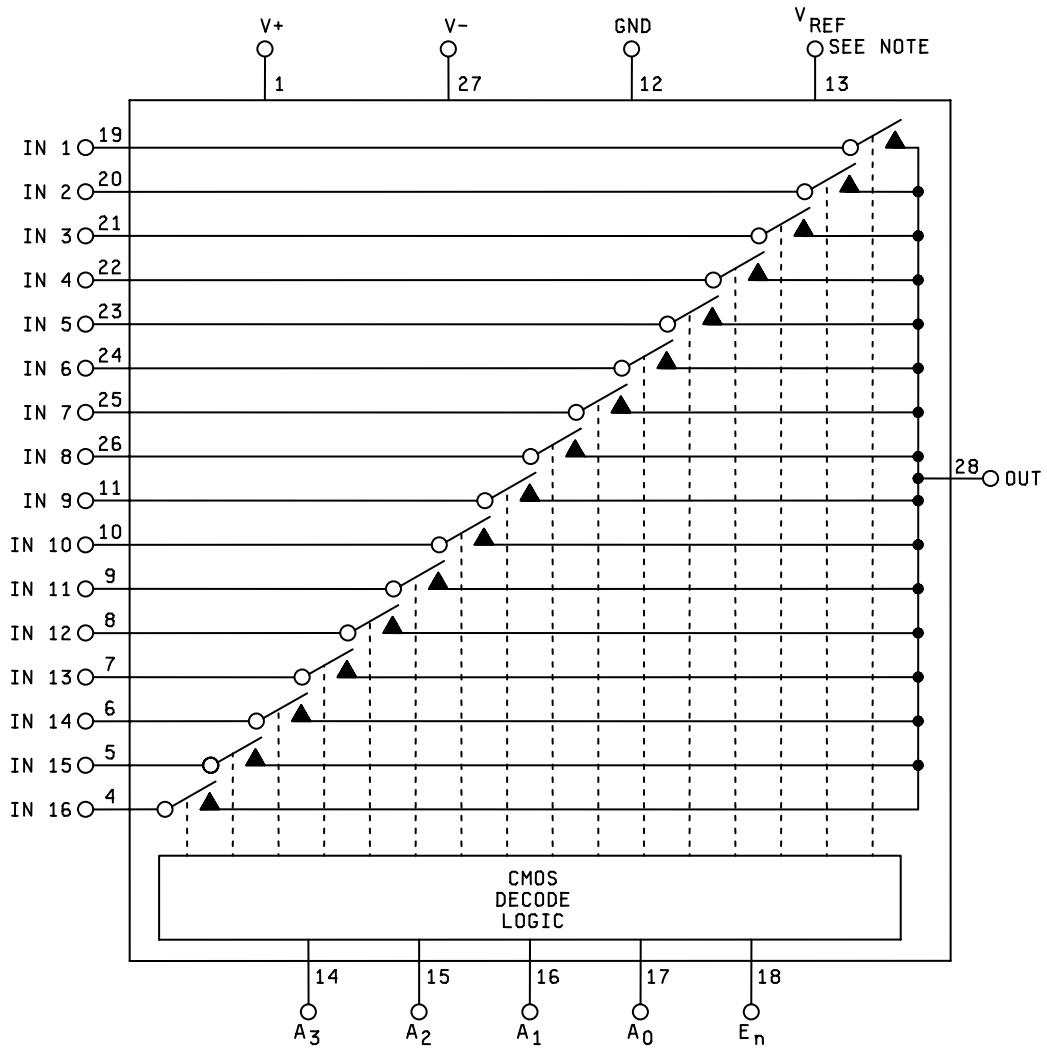

Figure 1. Terminal connections – Continued.

Device types 01 and 02



NOTE: Optional (normally left open)

FIGURE 2. Functional diagrams.

Device types 03 and 04

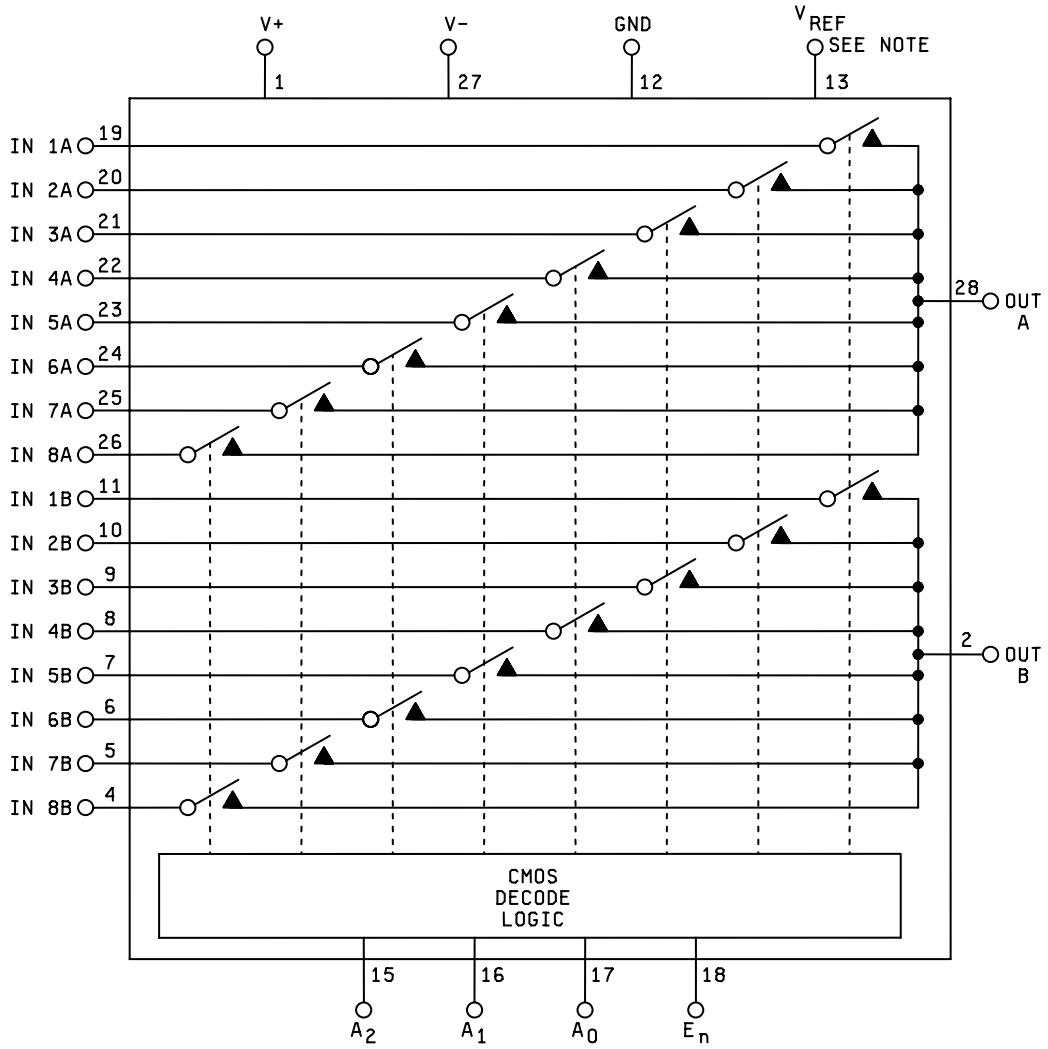

NOTE: Optional (normally left open)

FIGURE 2. Functional diagrams – Continued.

Device types 05 and 07

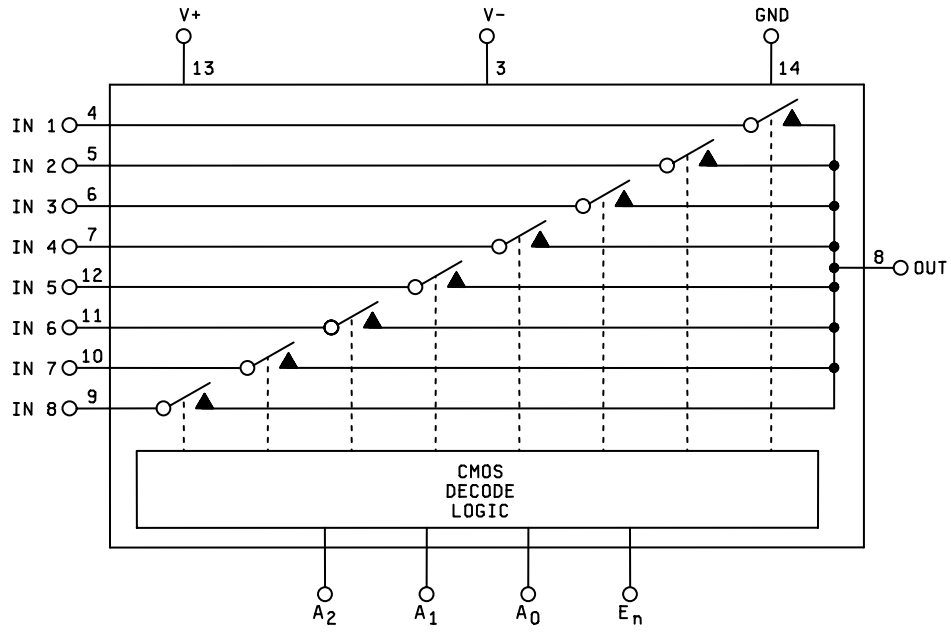

Device types 06 and 08

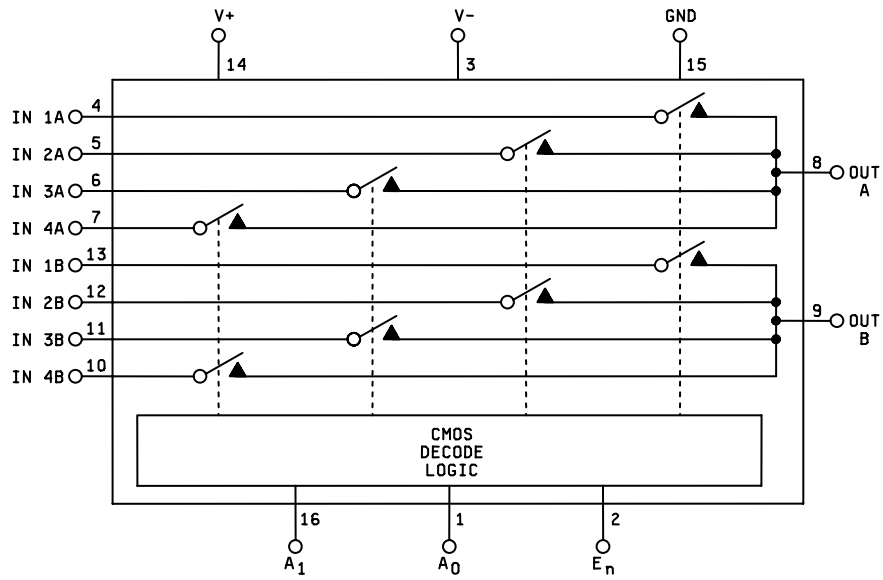

FIGURE 2. Functional diagrams – Continued.

Device types 01 and 02

A3	A2	A1	A0	EN	CHANNEL SELECTED
X	X	X	X	L	NONE
L	L	L	L	H	1
L	L	L	H	H	2
L	L	H	L	H	3
L	L	H	H	H	4
L	H	L	L	H	5
L	H	L	H	H	6
L	H	H	L	H	7
L	H	H	H	H	8
H	L	L	L	H	9
H	L	L	H	H	10
H	L	H	L	H	11
H	L	H	H	H	12
H	H	L	L	H	13
H	H	L	H	H	14
H	H	H	L	H	15
H	H	H	H	H	16

Device types 03 and 04

A2	A1	A0	EN	CHANNEL SELECTED
X	X	X	L	NONE
L	L	L	H	1A, 1B
L	L	H	H	2A, 2B
L	H	L	H	3A, 3B
L	H	H	H	4A, 4B
H	L	L	H	5A, 5B
H	L	H	H	6A, 6B
H	H	L	H	7A, 7B
H	H	H	H	8A, 8B

FIGURE 3. Truth tables.

Device types 05 and 07

A2	A1	A0	EN	CHANNEL SELECTED
X	X	X	L	NONE
L	L	L	H	1
L	L	H	H	2
L	H	L	H	3
L	H	H	H	4
H	L	L	H	5
H	L	H	H	6
H	H	L	H	7
H	H	H	H	8

Device types 06 and 08

A1	A0	EN	CHANNEL SELECTED
X	X	L	NONE
L	L	H	1A, 1B
L	H	H	2A, 2B
H	L	H	3A, 3B
H	H	H	4A, 4B

FIGURE 3. Truth tables – Continued.

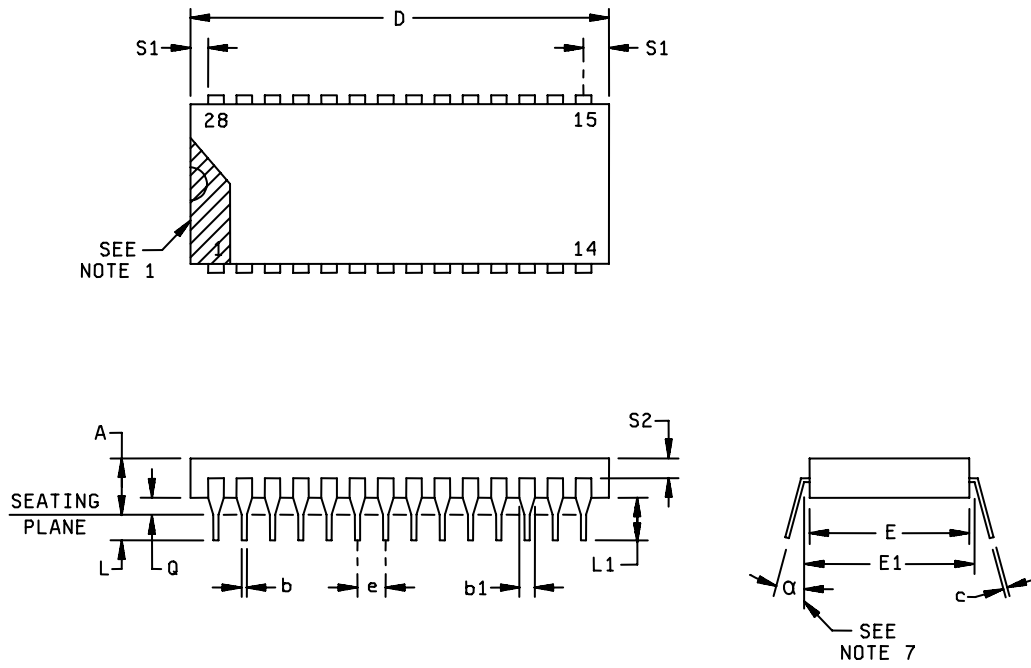

FIGURE 4. Case outline X.

Symbol	Inches		Millimeters		Notes
	Min	Max	Min	Max	
A	----	.200	----	5.08	
b	.014	.023	0.36	0.58	8
b ₁	.040	.070	1.02	1.78	2, 8
C	.008	.014	.20	0.36	8
D	----	1.48	----	37.6	4
E	.520	.610	13.21	13.97	4
E ₁	.585	.620	14.86	15.75	7
E ₂	N/A	N/A	N/A	N/A	
E ₃	N/A	N/A	N/A	N/A	
e	.100 BSC		2.54 BSC		5, 9
L	.125	.200	3.18	5.08	
L ₁	.150		3.81	5.08	
Q	.015	.060	0.51	1.52	3
Q ₁	N/A	N/A	N/A	N/A	
S	----	.098	----	2.49	6
S ₁	.005	----	0.13	----	6
S ₂	.005	----	0.13	N/A	
α	0°	15°	0°	15°	

NOTES:

1. Index area; a notch or a pin one identification mark shall be located adjacent to pin one and shall be located within the shaded area shown. The manufacturer's identification shall not be used as a pin one identification mark.
2. The minimum limit for dimension b₁ may be .023 (.58 mm) for leads number 1, 14, 15, and 28 only.
3. Dimension Q shall be measured from the seating plane to the base plane.
4. This dimension allows for off-center lid, meniscus and glass overrun.
5. The basic pin spacing is .100 (2.54 mm) between centerlines. Each pin centerline shall be located within ±.010 (.25 mm) of its exact longitudinal position relative to pins 1 and 28.
6. Applies to all four corners (leads number 1, 14, 15, and 28).
7. Lead center when α = 0°. E₁ shall be measured at the centerline of the leads.
8. All leads – Increase maximum limit by .003 (.08 mm) measured at the center of the flat, when lead finish A or B is applied.
9. Twenty six spaces.
10. If this configuration is used, no organic or polymeric materials shall be molded to the bottom of the package to cover the leads.

FIGURE 4. Case outline X – Continued.

Device types 02, 04, 05, and 06

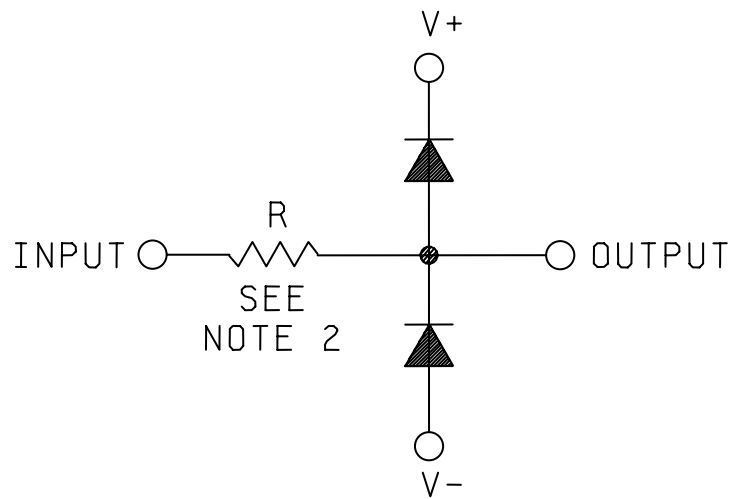

NOTES:

1. All device inputs shall be protected from transients such as electrostatic discharge. This circuit is intrinsic to the device.
2. This resistance is 200 to 2,000 Ω depending on device type.

FIGURE 5. Address and Enable input protection circuit.

Device types 01 and 02
Address inputs to I/O

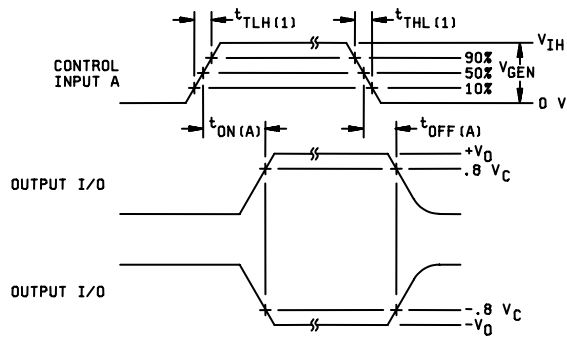
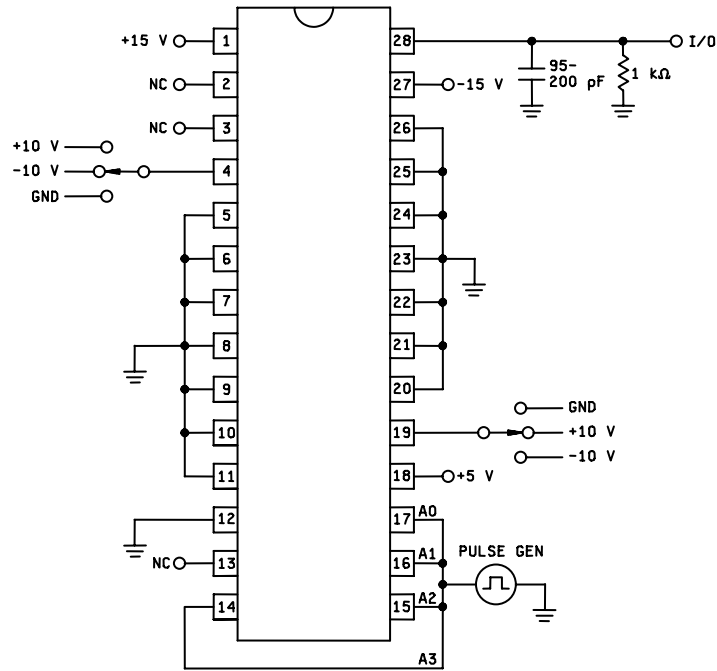

Input pulse requirements:
 $V_{GEN} = 4 V$
 $t_{THL(1)} = t_{TLH(1)} \leq 20 ns$

DYNAMIC TEST WAVEFORMS

FIGURE 6. Switching time test circuit and waveforms.

Device types 01 and 02
Enable to I/O

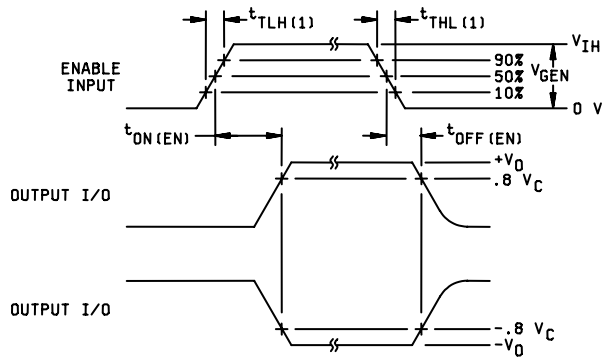
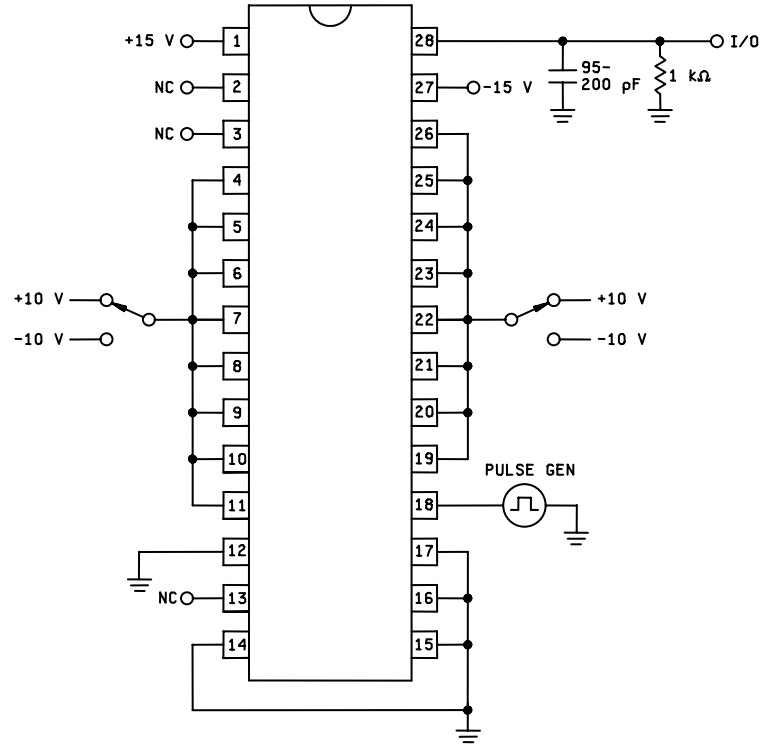

Input pulse requirements:
 $V_{GEN} = 4 \text{ V}$
 $t_{THL(1)} = t_{TLH(1)} \leq 20 \text{ ns}$

DYNAMIC TEST WAVEFORMS

FIGURE 7. Switching time test circuit and waveforms.

Device types 03 and 04
Address inputs to I/O

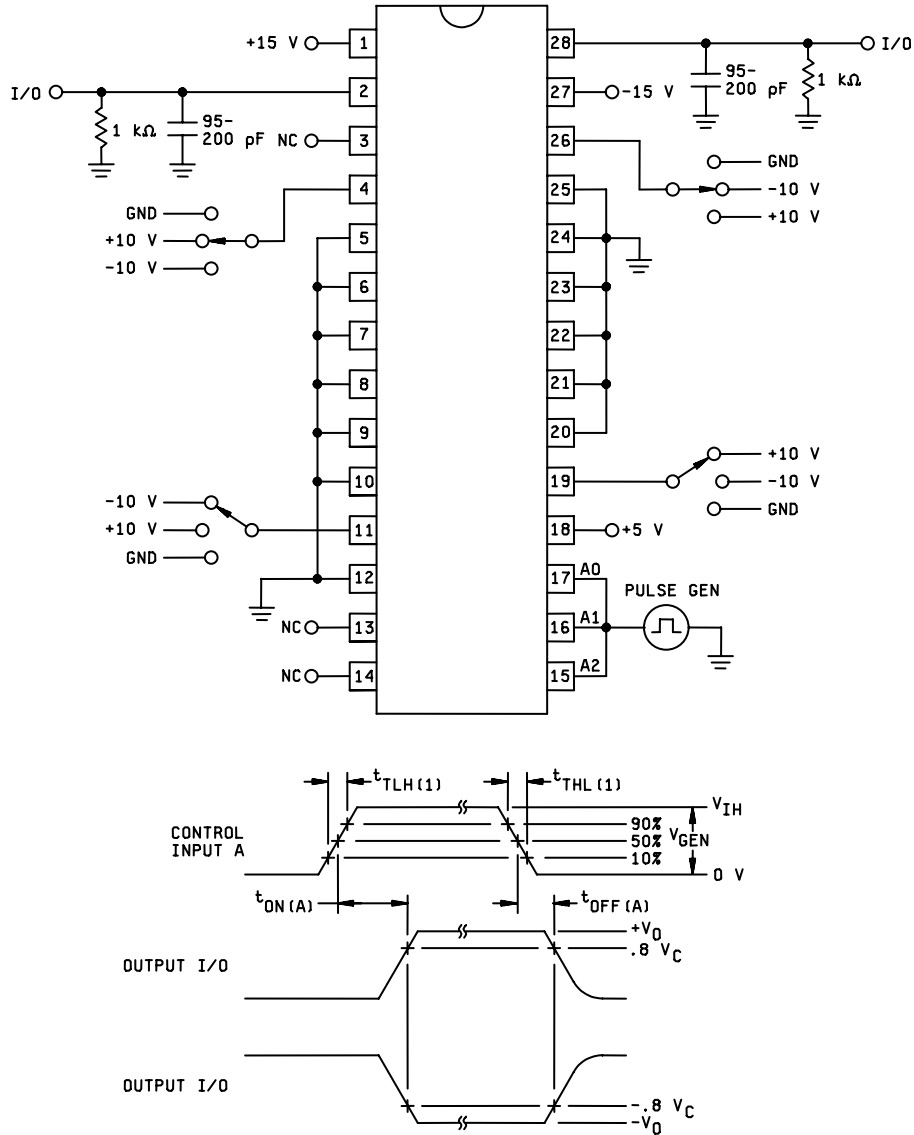

Input pulse requirements:
 $V_{GEN} = 4 V$
 $t_{THL(1)} = t_{TLH(1)} \leq 20 ns$

DYNAMIC TEST WAVEFORMS

FIGURE 8. Switching time test circuit and waveforms.

Device types 03 and 04
 Enable to I/O

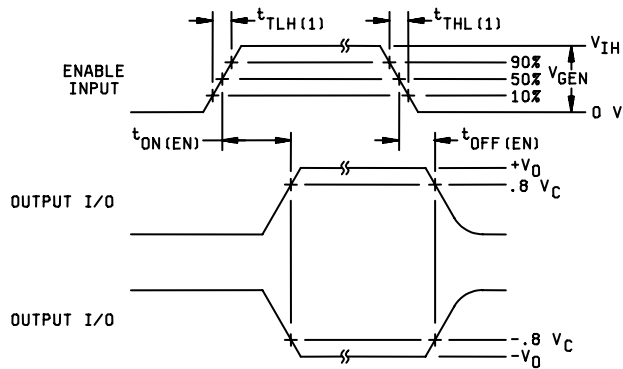
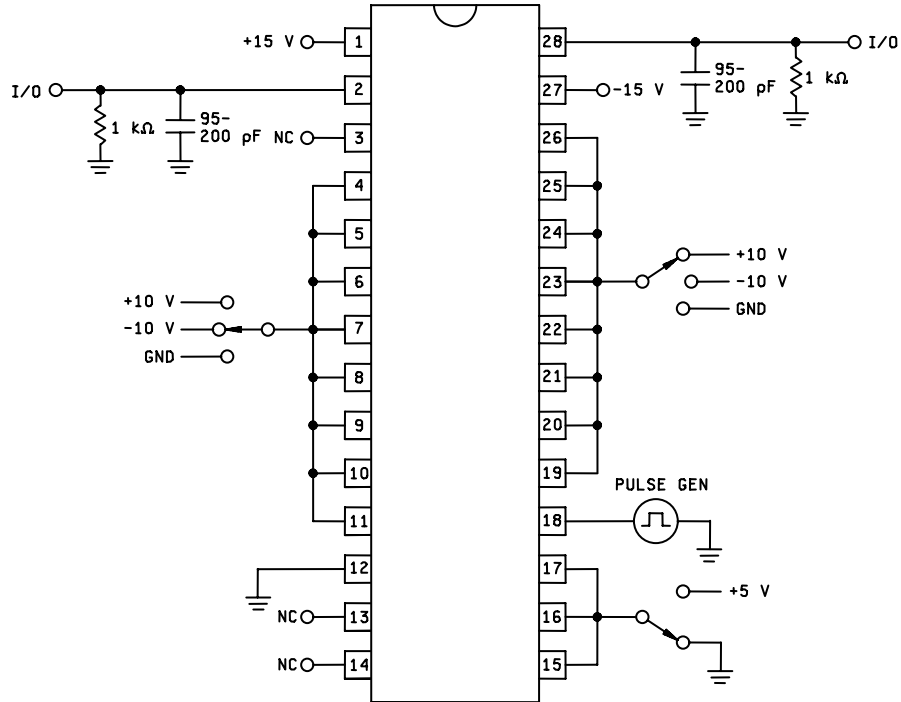

Input pulse requirements:
 $V_{GEN} = 4 V$
 $t_{THL(1)} = t_{TLH(1)} \leq 20 ns$

DYNAMIC TEST WAVEFORMS

FIGURE 9. Switching time test circuit and waveforms.

Device types 05 and 07
Address inputs to I/O

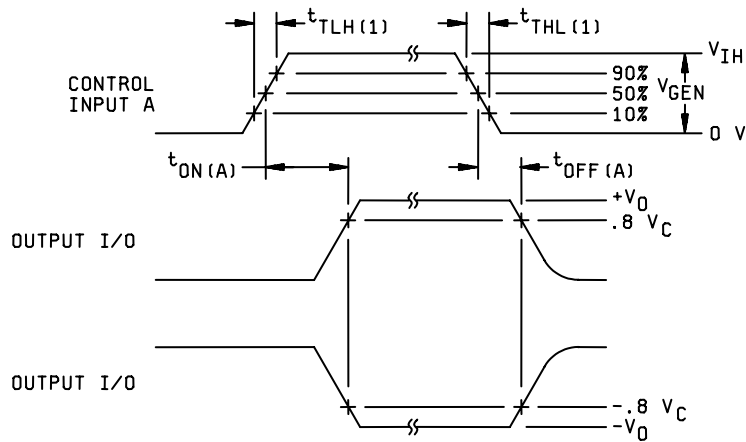
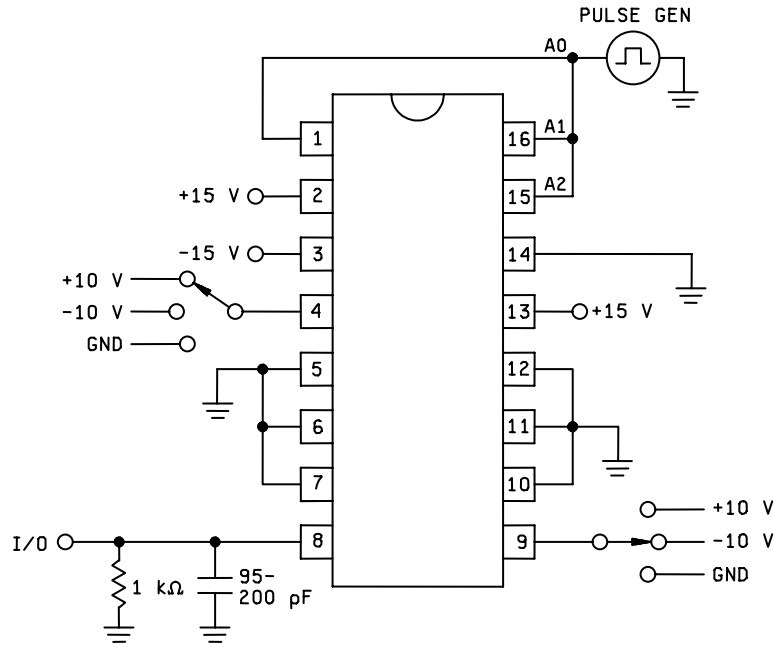

Input pulse requirements:
 $V_{GEN} = 4 V$
 $t_{THL(1)} = t_{TLH(1)} \leq 20 ns$

DYNAMIC TEST WAVEFORMS

FIGURE 10. Switching time test circuit and waveforms.

Device types 05 and 07
 Enable to I/O

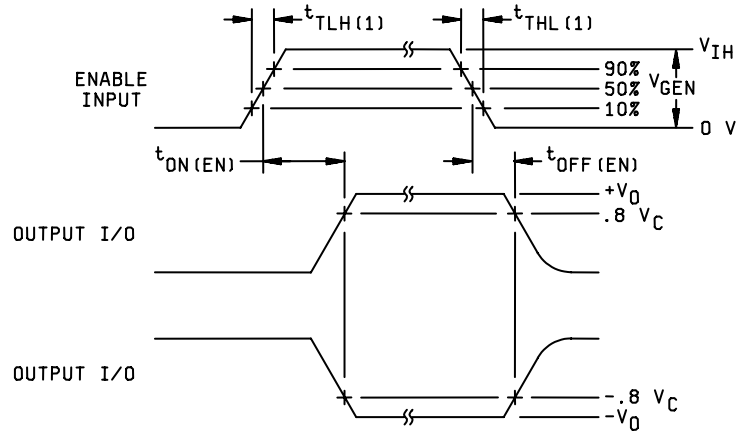
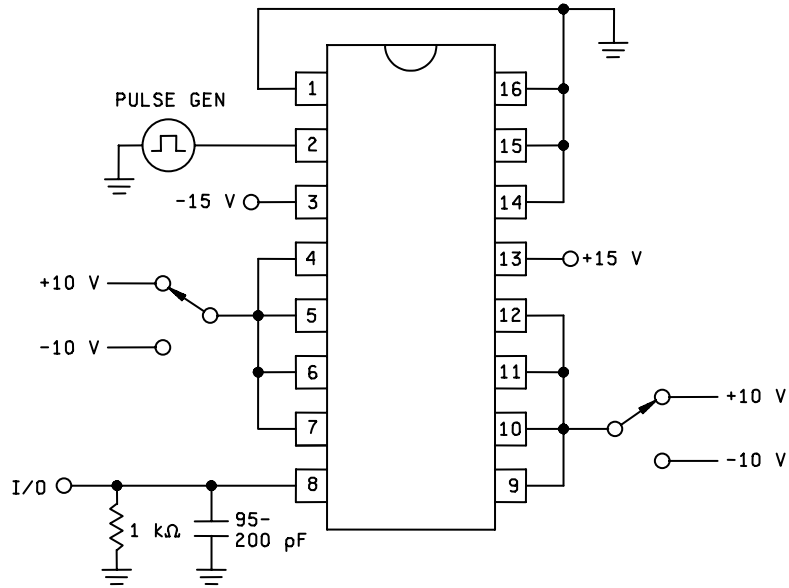

DYNAMIC TEST WAVEFORMS

Input pulse requirements:
 $V_{GEN} = 4 \text{ V}$
 $t_{THL(1)} = t_{TLH(1)} \leq 20 \text{ ns}$

FIGURE 11. Switching time test circuit and waveforms.

Device types 06 and 08
Address inputs to I/O

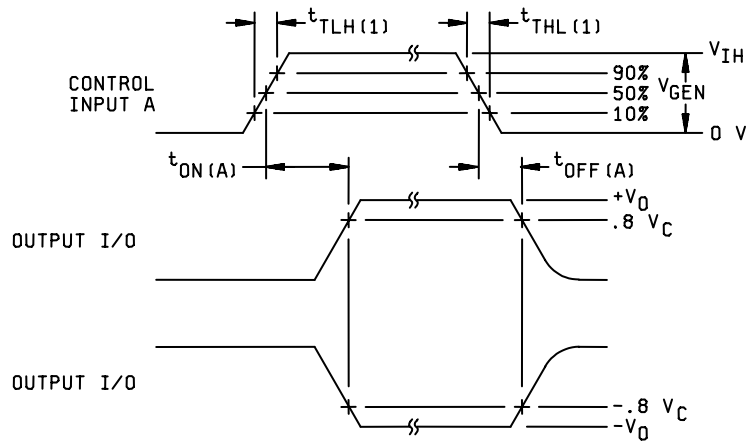
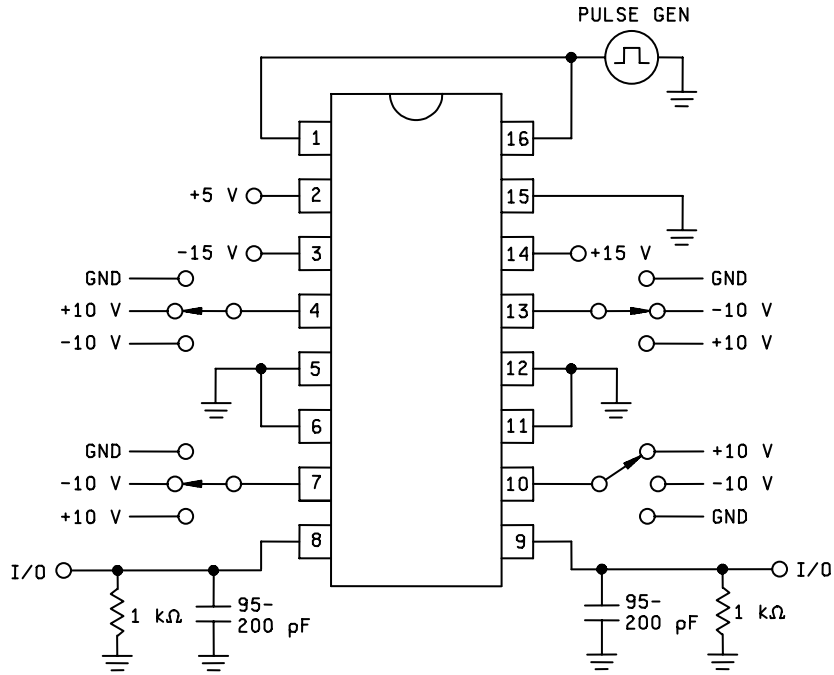

Input pulse requirements:
 $V_{GEN} = 4 \text{ V}$
 $t_{THL(1)} = t_{TLH(1)} \leq 20 \text{ ns}$

DYNAMIC TEST WAVEFORMS

FIGURE 12. Switching time test circuit and waveforms.

Device types 06 and 08
 Enable to I/O

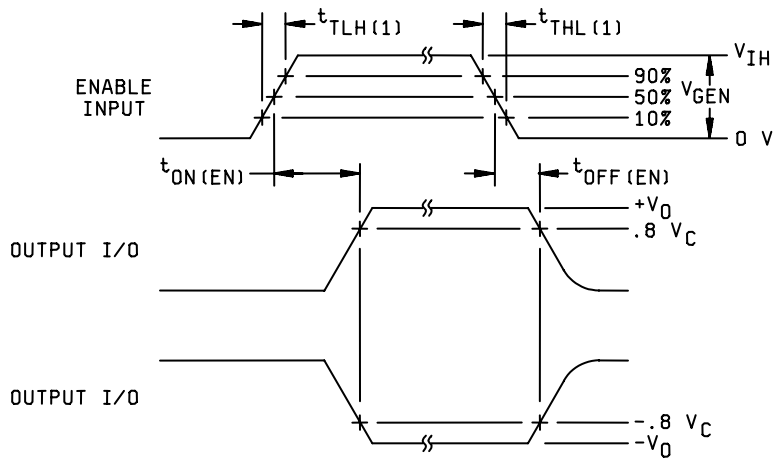
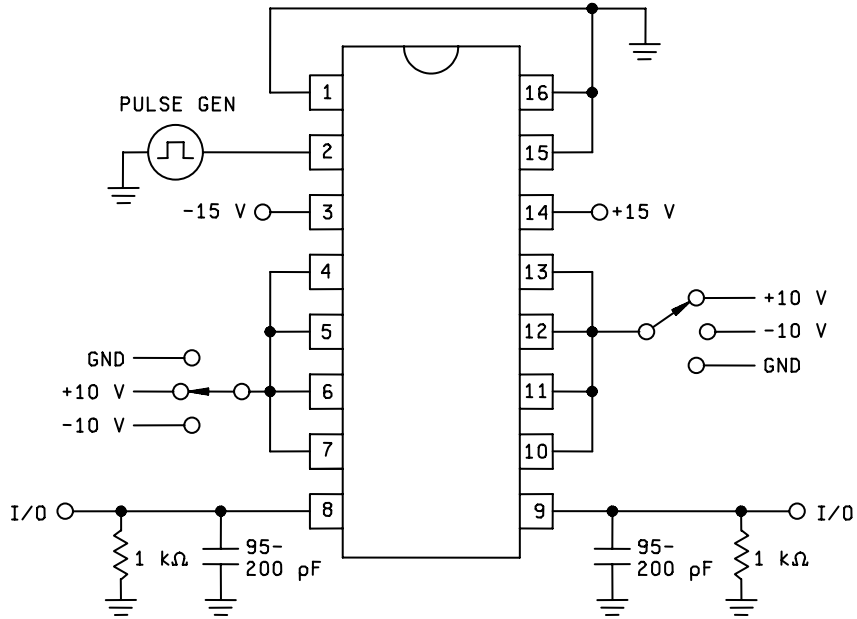

Input pulse requirements:
 $V_{GEN} = 4 V$
 $t_{THL(1)} = t_{TLH(1)} \leq 20 ns$

DYNAMIC TEST WAVEFORMS

FIGURE 13. Switching time test circuit and waveforms.

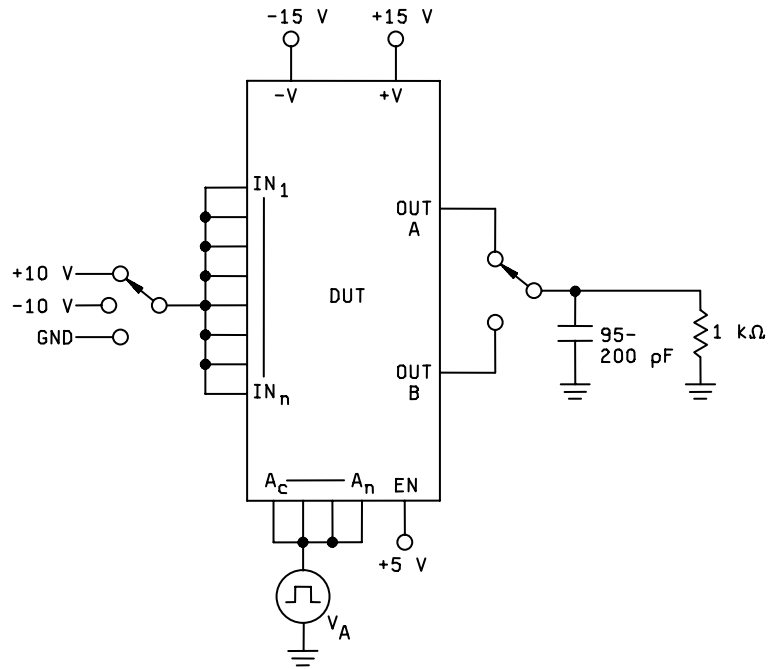

Input pulse requirements:
 $V_{GEN} = 4 \text{ V}$
 $t_{THL(1)} = t_{TLH(1)} \leq 20 \text{ ns}$

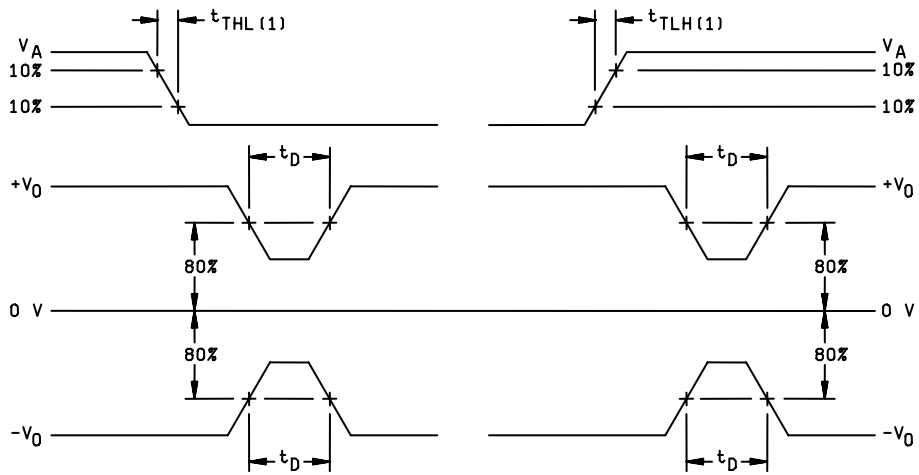
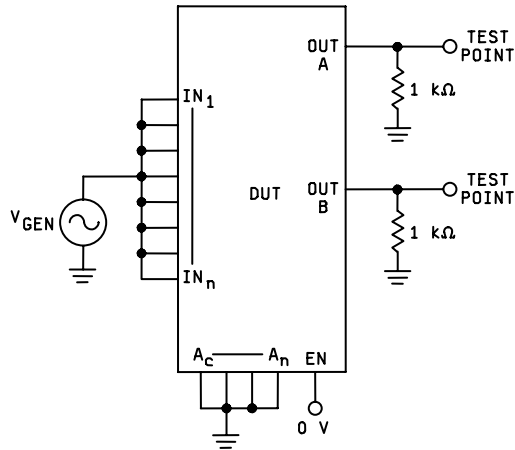
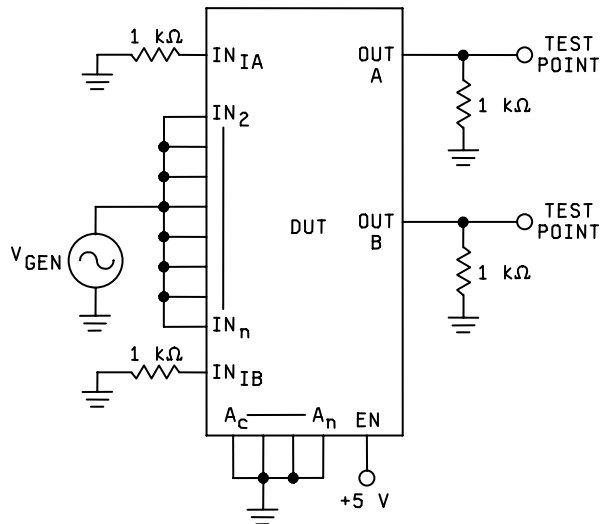

FIGURE 14. Break before make test circuit and waveforms.



NOTE: The pulse generator has the following characteristics: $V_{GEN} = 1\text{ V}_{P-P}$, $PRR = 200\text{ kHz}$.

FIGURE 15. Single channel isolation test circuit.



NOTE: The pulse generator has the following characteristics: $V_{GEN} = 1\text{ V}_{P-P}$, $PRR = 200\text{ kHz}$.

FIGURE 16. Crosstalk test circuit.

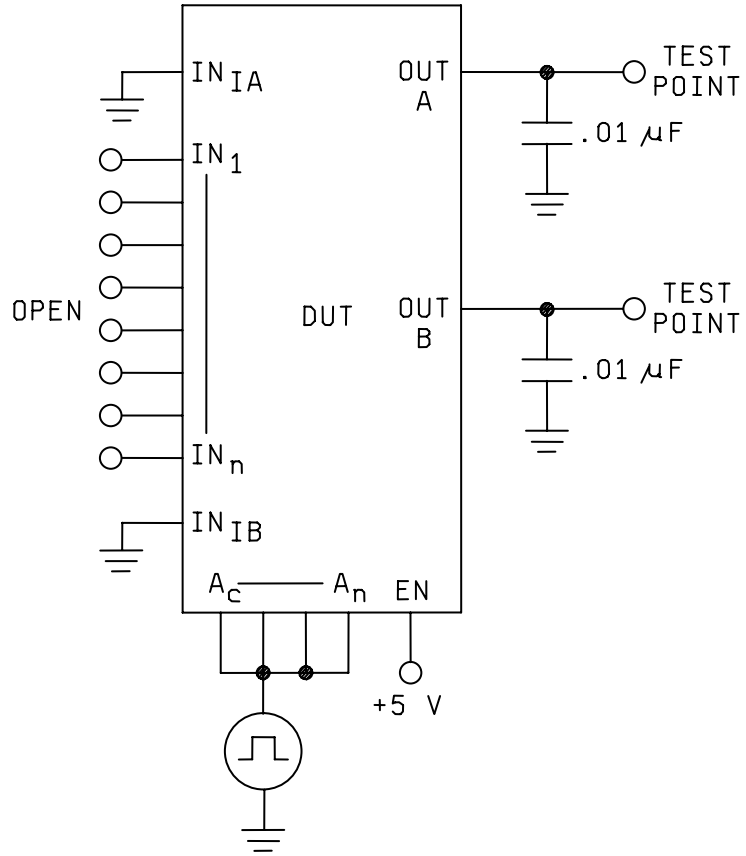

NOTE: The pulse generator has the following characteristics: $V_{\text{GEN}} = 0 - 5 \text{ V}$.

FIGURE 17. Charge transfer error test circuit.

TABLE III. Group A inspection for device type 01.

Symbol	MIL-STD-883 method	Case X	Terminal conditions 1/														Measured Terminal	Test limits						Unit				
			1	2	3	4	5	6	7	8	9	10	11	12	13	14		Subgroup 1 T _A = 25°C		Subgroup 2 T _A = 125°C		Subgroup 3 T _A = -55°C						
			Test no.	V+	NC	NC	IN16	IN15	IN14	IN13	IN12	IN11	IN10	IN9	GND	NC		A3	Min	Max	Min	Max	Min		Max			
I _{IH} 2/	3010	1	15 V														GND			2.4 V	A3	-0.1	1.0	-0.1	1.0	-0.1	1.0	μA
		2																	GND	A2								
		3																		A1								
		4																		A0								
		5																		EN								
I _{IL} 2/	3009	6																0.8 V	A3	-1.0	0.1	-1.0	0.1	-1.0	0.1			
		7																5 V	A2									
		8																	A1									
		9																	A0									
		10																	EN									
I _{S(OFF)} 3/		11				-10 V	-10 V	-10 V	-10 V	-10 V	-10 V	-10 V					0.8 V	IN1	-1	1	-50	50	-50	50	nA			
		12																	IN2									
		13																	IN3									
		14																	IN4									
		15																	IN5									
		16																	IN6									
		17																	IN7									
		18																	IN8									
		19																10 V	IN9									
		20																-10 V	IN10									
		21																10 V	IN11									
		22																-10 V	IN12									
		23																10 V	IN13									
		24																-10 V	IN14									
		25																10 V	IN15									
		26																-10 V	IN16									
		27																10 V	IN1									
		28																10 V	IN2									
		29																10 V	IN3									
		30																10 V	IN4									
		31																10 V	IN5									
		32																10 V	IN6									
		33																10 V	IN7									
		34																10 V	IN8									
		35																10 V	IN9									
		36																-10 V	IN10									
		37																10 V	IN11									
		38																-10 V	IN12									
39																10 V	IN13											
40																-10 V	IN14											
41																10 V	IN15											
42																-10 V	IN16											
I _{D(OFF)}		43				-10 V	10 V	10 V								10 V	OUT	-20	20	-500	500	-500	500					
I _{D+(OFF)}		44				-10 V	-10 V	-10 V	-10 V	-10 V	-10 V	-10 V					OUT											
I _{D+(ON)}		45															IN1 & OUT											
		46															IN2 & OUT											
		47															IN3 & OUT											
		48															IN4 & OUT											
		49															IN5 & OUT											
		50															IN6 & OUT											
		51															IN7 & OUT											

See footnotes at end of table.

TABLE III. Group A inspection for device type 01 – Continued.

Symbol	Case X	Terminal conditions 1/														Measured Terminal	Test limits						Unit	
		15	16	17	18	19	20	21	22	23	24	25	26	27	28		Subgroup 1 T _A = 25°C		Subgroup 2 T _A = 125°C		Subgroup 3 T _A = -55°C			
		Test no.	A2	A1	A0	EN	IN1	IN2	IN3	IN4	IN5	IN6	IN7	IN8	V-		OUT	Min	Max	Min	Max	Min		Max
I _{IH} 2/	1	GND	GND	GND	GND									-15 V		A3	-0.1	1.0	-0.1	1.0	-0.1	1.0	μA	
	2	2.4 V	GND	GND												A2								
	3	GND	2.4 V	GND												A1								
	4	GND	GND	2.4 V												A0								
	5	GND	GND	GND	2.4 V											EN								
I _{IL} 2/	6	5 V	5 V	5 V	5 V											A3	-1.0	0.1	-1.0	0.1	-1.0	0.1		
	7	0.8 V	5 V													A2								
	8	5 V	0.8 V													A1								
	9	5 V	5 V	0.8 V												A0								
	10	5 V	5 V	5 V	0.8 V											EN								
I _{SI(OFF)} 3/	11	0.8 V	0.8 V	0.8 V	0.8 V	10 V	-10 V	-10 V	-10 V	-10 V	-10 V	-10 V	-10 V		-10 V	IN1	-1	1	-50	50	-50	50	nA	
	12		0.8 V	2.4 V		-10 V	10 V	-10 V	-10 V							IN2								
	13		2.4 V	0.8 V			-10 V	10 V	-10 V	-10 V						IN3								
	14		2.4 V	2.4 V				-10 V	10 V							IN4								
	15	2.4 V	0.8 V	0.8 V					-10 V	10 V						IN5								
	16		0.8 V	2.4 V						-10 V	10 V					IN6								
	17		2.4 V	0.8 V							-10 V	10 V				IN7								
	18		2.4 V	2.4 V								-10 V	10 V			IN8								
	19	0.8 V	0.8 V	0.8 V									-10 V	10 V		IN9								
	20		0.8 V	2.4 V										-10 V		IN10								
	21		2.4 V	0.8 V												IN11								
	22		2.4 V	2.4 V												IN12								
	23	2.4 V	0.8 V	0.8 V												IN13								
	24		0.8 V	2.4 V												IN14								
	25		2.4 V	0.8 V												IN15								
	26		2.4 V	2.4 V												IN16								
	27	0.8 V	0.8 V	0.8 V	0.8 V		10 V	10 V	10 V	10 V	10 V	10 V	10 V		10 V	IN1								
	28		0.8 V	2.4 V		10 V	-10 V	10 V	10 V							IN2								
	29		2.4 V	0.8 V			10 V	-10 V	10 V							IN3								
	30		2.4 V	2.4 V				10 V	-10 V							IN4								
	31	2.4 V	0.8 V	0.8 V					10 V	-10 V						IN5								
	32		0.8 V	2.4 V						10 V	-10 V					IN6								
	33		2.4 V	0.8 V							10 V	-10 V				IN7								
	34		2.4 V	2.4 V								10 V	-10 V			IN8								
	35	0.8 V	0.8 V	0.8 V									10 V			IN9								
	36		0.8 V	2.4 V												IN10								
	37		2.4 V	0.8 V												IN11								
	38		2.4 V	2.4 V												IN12								
	39	2.4 V	0.8 V	0.8 V												IN13								
	40		0.8 V	2.4 V												IN14								
	41		2.4 V	0.8 V												IN15								
42		2.4 V	2.4 V												IN16									
I _{D-(OFF)}	43	0.8 V	0.8 V	0.8 V										-10 V	OUT	-20	20	-500	500	-500	500			
I _{D+(OFF)}	44			0.8 V		-10 V	-10 V	-10 V	-10 V	-10 V	-10 V	-10 V		10 V	OUT									
I _{D+(ON)}	45			0.8 V	4.5 V	10 V	-10 V	-10 V							IN1 & OUT									
	46			2.4 V		-10 V	10 V	10 V							IN2 & OUT									
	47		2.4 V	0.8 V			-10 V	-10 V							IN3 & OUT									
	48		2.4 V	2.4 V					10 V						IN4 & OUT									
	49	2.4 V	0.8 V	0.8 V					-10 V	10 V					IN5 & OUT									
	50	2.4 V	0.8 V	2.4 V					-10 V	-10 V	10 V				IN6 & OUT									
	51	2.4 V	2.4 V	0.8 V					-10 V	-10 V	-10 V				IN7 & OUT									

See footnotes at end of table.

TABLE III. Group A inspection for device types 01 – Continued.

Symbol	MIL-STD-883 method	Case X	Terminal conditions 1/														Measured Terminal	Test limits						Unit
			1	2	3	4	5	6	7	8	9	10	11	12	13	14		Subgroup 1 T _A = 25°C		Subgroup 2 T _A = 125°C		Subgroup 3 T _A = -55°C		
			Test no.	V+	NC	NC	IN16	IN15	IN14	IN13	IN12	IN11	IN10	IN9	GND	NC		A3	Min	Max	Min	Max	Min	
I _{D+(ON)}		52	15 V			-10 V	-10 V	-10 V	-10 V	-10 V	-10 V	-10 V	-10 V	GND		0.8 V	IN8 & OUT	-20	20	-500	500	-500	500	nA
		53	“			“	“	“	“	“	“	-10 V	-10 V	10 V	“	2.4 V	IN9 & OUT	“	“	“	“	“	“	“
		54	“			“	“	“	“	“	“	-10 V	10 V	-10 V	“	“	IN10 & OUT	“	“	“	“	“	“	“
		55	“			“	“	“	“	“	“	10 V	-10 V	“	“	“	IN11 & OUT	“	“	“	“	“	“	“
		56	“			“	“	“	“	“	“	10 V	-10 V	“	“	“	IN12 & OUT	“	“	“	“	“	“	“
		57	“			“	“	“	“	“	“	10 V	-10 V	“	“	“	IN13 & OUT	“	“	“	“	“	“	“
		58	“			“	“	“	“	“	“	10 V	-10 V	“	“	“	IN14 & OUT	“	“	“	“	“	“	“
		59	“			“	“	“	“	“	“	10 V	-10 V	-10 V	“	“	IN15 & OUT	“	“	“	“	“	“	“
		60	“			“	“	“	“	“	“	10 V	-10 V	-10 V	“	“	IN16 & OUT	“	“	“	“	“	“	“
	I _{D-(ON)}		61	“			10 V	10 V	10 V	10 V	10 V	10 V	10 V	10 V	“	0.8 V	IN1 & OUT	“	“	“	“	“	“	“
		62	“			“	“	“	“	“	“	“	“	“	“	“	IN2 & OUT	“	“	“	“	“	“	“
		63	“			“	“	“	“	“	“	“	“	“	“	“	IN3 & OUT	“	“	“	“	“	“	“
		64	“			“	“	“	“	“	“	“	“	“	“	“	IN4 & OUT	“	“	“	“	“	“	“
		65	“			“	“	“	“	“	“	“	“	“	“	“	IN5 & OUT	“	“	“	“	“	“	“
		66	“			“	“	“	“	“	“	“	“	“	“	“	IN6 & OUT	“	“	“	“	“	“	“
		67	“			“	“	“	“	“	“	“	“	“	“	“	IN7 & OUT	“	“	“	“	“	“	“
		68	“			“	“	“	“	“	“	“	“	“	“	“	IN8 & OUT	“	“	“	“	“	“	“
		69	“			“	“	“	“	“	“	“	“	-10 V	“	2.4 V	IN9 & OUT	“	“	“	“	“	“	“
		70	“			“	“	“	“	“	“	-10 V	10 V	“	“	“	IN10 & OUT	“	“	“	“	“	“	“
		71	“			“	“	“	“	“	“	-10 V	10 V	“	“	“	IN11 & OUT	“	“	“	“	“	“	“
		72	“			“	“	“	“	“	“	-10 V	10 V	“	“	“	IN12 & OUT	“	“	“	“	“	“	“
		73	“			“	“	“	“	“	“	-10 V	10 V	“	“	“	IN13 & OUT	“	“	“	“	“	“	“
		74	“			“	“	“	“	“	“	-10 V	10 V	“	“	“	IN14 & OUT	“	“	“	“	“	“	“
		75	“			“	“	“	“	“	“	-10 V	10 V	10 V	“	“	IN15 & OUT	“	“	“	“	“	“	“
		76	“			“	“	“	“	“	“	-10 V	10 V	10 V	“	“	IN16 & OUT	“	“	“	“	“	“	“
I+		77	“											“	0 V	V+	“	14		14		14	mA	
I-		78	“											“		V-	-14		-14		-14			
I+SBY		79	“											“		V+		3.0		3.0		3.0		
I-SBY		80	“											“		V-	-4.0		-4.0		-4.0			
R _{DS1}		81	“												“	“	IN1 & OUT		600		700		600	Ω
		82	“												“	“	IN2 & OUT							
		83	“												“	“	IN3 & OUT							
		84	“												“	“	IN4 & OUT							
		85	“												“	“	IN5 & OUT							
		86	“												“	“	IN6 & OUT							
		87	“												“	“	IN7 & OUT							
		88	“												“	“	IN8 & OUT							
		89	“											10 V	“	2.4 V	IN9 & OUT							
		90	“										10 V	“	“	“	IN10 & OUT							
		91	“									10 V	“	“	“	“	IN11 & OUT							
		92	“									10 V	“	“	“	“	IN12 & OUT							
		93	“									10 V	“	“	“	“	IN13 & OUT							
		94	“									10 V	“	“	“	“	IN14 & OUT							
		95	“									10 V	“	“	“	“	IN15 & OUT							
		96	“									10 V	“	“	“	“	IN16 & OUT							
		97	“												0.8 V	“	IN1 & OUT							
	98	“												“	“	IN2 & OUT								
	99	“												“	“	IN3 & OUT								
	100	“												“	“	IN4 & OUT								
	101	“												“	“	IN5 & OUT								

See footnotes at end of table.

TABLE III. Group A inspection for device type 01 – Continued.

Symbol	Case X	Terminal conditions 1/														Measured Terminal	Test limits						Unit
		15	16	17	18	19	20	21	22	23	24	25	26	27	28		Subgroup 1 T _A = 25°C		Subgroup 2 T _A = 125°C		Subgroup 3 T _A = -55°C		
		Test no.	A2	A1	A0	EN	IN1	IN2	IN3	IN4	IN5	IN6	IN7	IN8	V-		OUT	Min	Max	Min	Max	Min	
I _{D+(ON)}	52	2.4 V	2.4 V	2.4 V	4.5 V	-10 V	-10 V	-10 V	-10 V	-10 V	-10 V	-10 V	10 V	-15 V	10 V	IN8 & OUT	-20	20	-500	500	-500	500	nA
	53	0.8 V	0.8 V	0.8 V	“	“	“	“	“	“	“	“	“	“	“	IN9 & OUT	“	“	“	“	“	“	“
	54	“	0.8 V	2.4 V	“	“	“	“	“	“	“	“	“	“	“	IN10 & OUT	“	“	“	“	“	“	“
	55	“	2.4 V	0.8 V	“	“	“	“	“	“	“	“	“	“	“	IN11 & OUT	“	“	“	“	“	“	“
	56	“	2.4 V	2.4 V	“	“	“	“	“	“	“	“	“	“	“	IN12 & OUT	“	“	“	“	“	“	“
	57	2.4 V	0.8 V	0.8 V	“	“	“	“	“	“	“	“	“	“	“	IN13 & OUT	“	“	“	“	“	“	“
	58	“	0.8 V	2.4 V	“	“	“	“	“	“	“	“	“	“	“	IN14 & OUT	“	“	“	“	“	“	“
	59	“	2.4 V	0.8 V	“	“	“	“	“	“	“	“	“	“	“	IN15 & OUT	“	“	“	“	“	“	“
	60	“	2.4 V	2.4 V	“	“	“	“	“	“	“	“	“	“	“	IN16 & OUT	“	“	“	“	“	“	“
	I _{D-(ON)}	61	0.8 V	2.4 V	0.8 V	“	-10 V	10 V	10 V	10 V	10 V	10 V	10 V	10 V	“	-10 V	IN1 & OUT	“	“	“	“	“	“
62		“	0.8 V	2.4 V	“	10 V	-10 V	10 V	10 V	“	“	“	“	“	“	IN2 & OUT	“	“	“	“	“	“	“
63		“	2.4 V	0.8 V	“	“	10 V	-10 V	10 V	“	“	“	“	“	“	IN3 & OUT	“	“	“	“	“	“	“
64		“	2.4 V	2.4 V	“	“	“	10 V	-10 V	“	“	“	“	“	“	IN4 & OUT	“	“	“	“	“	“	“
65		2.4 V	0.8 V	0.8 V	“	“	“	“	10 V	-10 V	“	“	“	“	“	IN5 & OUT	“	“	“	“	“	“	“
66		“	0.8 V	2.4 V	“	“	“	“	“	10 V	-10 V	“	“	“	“	IN6 & OUT	“	“	“	“	“	“	“
67		“	2.4 V	0.8 V	“	“	“	“	“	“	10 V	-10 V	“	“	“	IN7 & OUT	“	“	“	“	“	“	“
68		“	2.4 V	2.4 V	“	“	“	“	“	“	“	10 V	-10 V	“	“	IN8 & OUT	“	“	“	“	“	“	“
69		0.8 V	0.8 V	0.8 V	“	“	“	“	“	“	“	“	10 V	“	“	IN9 & OUT	“	“	“	“	“	“	“
70		“	0.8 V	2.4 V	“	“	“	“	“	“	“	“	“	“	“	IN10 & OUT	“	“	“	“	“	“	“
71		“	2.4 V	0.8 V	“	“	“	“	“	“	“	“	“	“	“	IN11 & OUT	“	“	“	“	“	“	“
72		“	2.4 V	2.4 V	“	“	“	“	“	“	“	“	“	“	“	IN12 & OUT	“	“	“	“	“	“	“
73		2.4 V	0.8 V	0.8 V	“	“	“	“	“	“	“	“	“	“	“	IN13 & OUT	“	“	“	“	“	“	“
74		“	0.8 V	2.4 V	“	“	“	“	“	“	“	“	“	“	“	IN14 & OUT	“	“	“	“	“	“	“
75		“	2.4 V	0.8 V	“	“	“	“	“	“	“	“	“	“	“	IN15 & OUT	“	“	“	“	“	“	“
76		“	2.4 V	2.4 V	“	“	“	“	“	“	“	“	“	“	“	IN16 & OUT	“	“	“	“	“	“	“
I+	77	0 V	0 V	0 V	5 V	“	“	“	“	“	“	“	“	“	V+	“	14	“	14	“	14	“	mA
I-	78	“	“	“	5 V	“	“	“	“	“	“	“	“	“	V-	-14	“	-14	“	-14	“	“	“
I+SBY	79	“	“	“	0 V	“	“	“	“	“	“	“	“	“	V+	“	3.0	“	3.0	“	3.0	“	“
I-SBY	80	“	“	“	0 V	“	“	“	“	“	“	“	“	“	V-	-4.0	“	-4.0	“	-4.0	“	“	“
R _{DS1}	81	0.8 V	0.8 V	0.8 V	4.5 V	10 V	“	“	“	“	“	“	“	“	100 μA	IN1 & OUT	“	600	“	700	“	600	Ω
	82	“	0.8 V	2.4 V	“	“	10 V	“	“	“	“	“	“	“	“	IN2 & OUT	“	“	“	“	“	“	“
	83	“	2.4 V	0.8 V	“	“	“	10 V	“	“	“	“	“	“	“	IN3 & OUT	“	“	“	“	“	“	“
	84	“	2.4 V	2.4 V	“	“	“	“	10 V	“	“	“	“	“	“	IN4 & OUT	“	“	“	“	“	“	“
	85	2.4 V	0.8 V	0.8 V	“	“	“	“	“	10 V	“	“	“	“	“	IN5 & OUT	“	“	“	“	“	“	“
	86	“	0.8 V	2.4 V	“	“	“	“	“	“	10 V	“	“	“	“	IN6 & OUT	“	“	“	“	“	“	“
	87	“	2.4 V	0.8 V	“	“	“	“	“	“	“	10 V	“	“	“	IN7 & OUT	“	“	“	“	“	“	“
	88	“	2.4 V	2.4 V	“	“	“	“	“	“	“	“	10 V	“	“	IN8 & OUT	“	“	“	“	“	“	“
	89	0.8 V	0.8 V	0.8 V	“	“	“	“	“	“	“	“	“	“	“	IN9 & OUT	“	“	“	“	“	“	“
	90	“	0.8 V	2.4 V	“	“	“	“	“	“	“	“	“	“	“	IN10 & OUT	“	“	“	“	“	“	“
	91	“	2.4 V	0.8 V	“	“	“	“	“	“	“	“	“	“	“	IN11 & OUT	“	“	“	“	“	“	“
	92	“	2.4 V	2.4 V	“	“	“	“	“	“	“	“	“	“	“	IN12 & OUT	“	“	“	“	“	“	“
	93	2.4 V	0.8 V	0.8 V	“	“	“	“	“	“	“	“	“	“	“	IN13 & OUT	“	“	“	“	“	“	“
	94	“	0.8 V	2.4 V	“	“	“	“	“	“	“	“	“	“	“	IN14 & OUT	“	“	“	“	“	“	“
	95	“	2.4 V	0.8 V	“	“	“	“	“	“	“	“	“	“	“	IN15 & OUT	“	“	“	“	“	“	“
96	“	2.4 V	2.4 V	“	“	“	“	“	“	“	“	“	“	“	IN16 & OUT	“	“	“	“	“	“	“	
97	0.8 V	0.8 V	0.8 V	“	-10 V	“	“	“	“	“	“	“	“	“	-100 μA	IN1 & OUT	“	“	“	“	“	“	“
98	“	0.8 V	2.4 V	“	“	-10 V	“	“	“	“	“	“	“	“	“	IN2 & OUT	“	“	“	“	“	“	“
99	“	2.4 V	0.8 V	“	“	“	-10 V	“	“	“	“	“	“	“	“	IN3 & OUT	“	“	“	“	“	“	“
100	“	2.4 V	2.4 V	“	“	“	“	-10 V	“	“	“	“	“	“	“	IN4 & OUT	“	“	“	“	“	“	“
101	2.4 V	0.8 V	0.8 V	“	“	“	“	“	“	-10 V	“	“	“	“	“	IN5 & OUT	“	“	“	“	“	“	“

See footnotes at end of table.

TABLE III. Group A inspection for device type 01 – Continued.

Symbol	MIL-STD-883 method	Case X	Terminal conditions 1/														Measured Terminal	Test limits						Unit	
			1	2	3	4	5	6	7	8	9	10	11	12	13	14		Subgroup 1 T _A = 25°C		Subgroup 2 T _A = 125°C		Subgroup 3 T _A = -55°C			
			Test no.	V+	NC	NC	IN16	IN15	IN14	IN13	IN12	IN11	IN10	IN9	GND	NC		A3	Min	Max	Min	Max	Min		Max
R _{DS1}		102	15 V											GND		0.8 V	IN6 & OUT		600		700		600	Ω	
		103	"											"		"	IN7 & OUT		"		"		"	"	
		104	"											"		"	IN8 & OUT		"		"		"	"	
		105	"											-10 V	"	2.4 V	IN9 & OUT		"		"		"	"	
		106	"												-10 V	"	IN10 & OUT		"		"		"	"	
		107	"												-10 V	"	IN11 & OUT		"		"		"	"	
		108	"												-10 V	"	IN12 & OUT		"		"		"	"	
		109	"												-10 V	"	IN13 & OUT		"		"		"	"	
		110	"												-10 V	"	IN14 & OUT		"		"		"	"	
		111	"												-10 V	"	IN15 & OUT		"		"		"	"	
		112	"												-10 V	"	IN16 & OUT		"		"		"	"	
	R _{DS2}		113-128 - Same terminal conditions as for tests 81 thru 96, except V _± = ± 10 V, V _S = +7.5 V and limits as shown.															1		1		1	kΩ		
R _{DS2}		129-144 - Same terminal conditions as for tests 97 thru 112, except V _± = ± 10 V, V _S = -7.5 V and limits as shown.															1		1		1	kΩ			
																	Subgroup 4 T _A = 25°C								
																	Min	Max							
C _A	3012	145	GND											GND		4/	A3							pF	
	"	146	"											"			A2							"	
	"	147	"											"			A1							"	
	"	148	"											"			A0							"	
C _{OS}		149	"												0 V	OUT			90					"	
C _{IS}		150	"													"	IN1			10					"
		151	"													"	IN2			"					"
		152	"													"	IN3			"					"
		153	"													"	IN4			"					"
		154	"													"	IN5			"					"
		155	"													"	IN6			"					"
		156	"													"	IN7			"					"
		157	"													"	IN8			"					"
		158	"													4/	IN9			"					"
		159	"													4/	IN10			"					"
		160	"													4/	IN11			"					"
		161	"													4/	IN12			"					"
		162	"													4/	IN13			"					"
		163	"													4/	IN14			"					"
		164	"													4/	IN15			"					"
		165	"													4/	IN16			"					"
	C _{EN}		166	"												"	EN			"					"

See footnotes at end of table.

TABLE III. Group A inspection for device type 01 – Continued.

Symbol	MIL-STD-883 method	Case X	Terminal conditions 1/														Measured Terminal	Test limits						Unit					
			1	2	3	4	5	6	7	8	9	10	11	12	13	14		Subgroup 9 T _A = 25°C		Subgroup 10 T _A = 125°C		Subgroup 11 T _A = -55°C							
			Test no.	V+	NC	NC	IN16	IN15	IN14	IN13	IN12	IN11	IN10	IN9	GND	NC		A3	Min	Max	Min	Max	Min		Max				
t _{ON(A)} and t _{OFF(A)}	3003 fig. 6	167	15 V			-10 V	GND	GND	GND	GND	GND	GND	GND	GND	GND	GND	GND	ADDRESS		1,000			1,500			1,000	ns		
		168	"			10 V	"	"	"	"	"	"	"	"	"	"	"	"	IN TO OUT	"	"	"	"	"	"	"	"	"	
		169	"			-10 V	"	"	"	"	"	"	"	"	"	"	"	"	"	"	"	"	"	"	"	"	"	"	
		170	"			10 V	"	"	"	"	"	"	"	"	"	"	"	"	"	"	"	"	"	"	"	"	"	"	
		171	"			GND	"	"	"	"	"	"	"	"	"	"	"	"	"	"	"	"	"	"	"	"	"	"	
		172	"			"	"	"	"	"	"	"	"	"	"	"	"	"	"	"	"	"	"	"	"	"	"	"	"
		173	"			"	"	"	"	"	"	"	"	"	"	"	"	"	"	"	"	"	"	"	"	"	"	"	"
t _{ON(EN)} and t _{OFF(EN)}	fig. 7	175	"			-10 V	-10 V	-10 V	-10 V	-10 V	-10 V	-10 V	-10 V	-10 V	-10 V	GND	GND	ENABLE		"	"	"	"	"	"	"	"	"	
		176	"			10 V	10 V	10 V	10 V	10 V	10 V	10 V	10 V	10 V	10 V	"	"	TO OUT	"	"	"	"	"	"	"	"	"	"	
		177	"			-10 V	-10 V	-10 V	-10 V	-10 V	-10 V	-10 V	-10 V	-10 V	-10 V	"	"	"	"	"	"	"	"	"	"	"	"	"	"
		178	"			10 V	10 V	10 V	10 V	10 V	10 V	10 V	10 V	10 V	"	"	"	"	"	"	"	"	"	"	"	"	"	"	"
																		Subgroup 12 T _A = 25°C											
																		Min	Max										
V _{ISO}	fig. 15	179	15 V			IN	IN	IN	IN	IN	IN	IN	IN	IN	GND	GND	OUT		50									dB	
V _{CT}	fig. 16	180	15 V			IN	IN	IN	IN	IN	IN	IN	IN	IN	GND	GND	OUT		50									dB	
V _{CTE}	fig. 17	181	15 V												GND	IN	OUT			10								mV	
																		Subgroup 13 T _A = 25°C											
																		Min	Max										
t _D	fig. 14	182	15 V			10 V	10 V	10 V	10 V	10 V	10 V	10 V	10 V	10 V	GND	GND	OUT		5									ns	
		183	"			-10 V	-10 V	-10 V	-10 V	-10 V	-10 V	-10 V	-10 V	-10 V	"	"	"	"	"	"	"	"	"	"	"	"	"	"	"
		184	"			10 V	10 V	10 V	10 V	10 V	10 V	10 V	10 V	10 V	"	"	"	"	"	"	"	"	"	"	"	"	"	"	"
		185	"			-10 V	-10 V	-10 V	-10 V	-10 V	-10 V	-10 V	-10 V	-10 V	"	"	"	"	"	"	"	"	"	"	"	"	"	"	"

See footnotes at end of table.

TABLE III. Group A inspection for device type 01 – Continued.

Symbol	MIL-STD-883 method	Case X	Terminal conditions 1/														Measured Terminal	Test limits						Unit					
			15	16	17	18	19	20	21	22	23	24	25	26	27	28		Subgroup 9 T _A = 25°C		Subgroup 10 T _A = 125°C		Subgroup 11 T _A = -55°C							
			Test no.	A2	A1	A0	EN	IN1	IN2	IN3	IN4	IN5	IN6	IN7	IN8	V-		OUT	Min	Max	Min	Max	Min		Max				
t _{ON(A)} and t _{OFF(A)}		167				5 V	GND	GND	GND	GND	GND	GND	GND	GND	GND	GND	GND	-15 V	OUT	ADDRESS IN TO OUT		1,000		1,500		1,000	ns		
		168				"	"	"	"	"	"	"	"	"	"	"	"	"	"	"	"	"	"	"	"	"	"		
		169				"	"	"	"	"	"	"	"	"	"	"	"	"	"	"	"	"	"	"	"	"	"	"	
		170				"	"	"	"	"	"	"	"	"	"	"	"	"	"	"	"	"	"	"	"	"	"	"	
		171				"	-10 V	"	"	"	"	"	"	"	"	"	"	"	"	"	"	"	"	"	"	"	"	"	
		172				"	10 V	"	"	"	"	"	"	"	"	"	"	"	"	"	"	"	"	"	"	"	"	"	
		173				"	-10 V	"	"	"	"	"	"	"	"	"	"	"	"	"	"	"	"	"	"	"	"	"	
	174				"	10 V	"	"	"	"	"	"	"	"	"	"	"	"	"	"	"	"	"	"	"	"	"		
t _{ON(EN)} and t _{OFF(EN)}		175	GND	GND	GND		-10 V	-10 V	-10 V	-10 V	-10 V	-10 V	-10 V	-10 V	-10 V	-10 V	-10 V	"	"	ENABLE TO OUT	"	"	"	"	"	"	"	"	
		176	"	"	"		10 V	10 V	10 V	10 V	10 V	10 V	10 V	10 V	10 V	10 V	10 V	"	"	"	"	"	"	"	"	"	"	"	
		177	"	"	"		-10 V	-10 V	-10 V	-10 V	-10 V	-10 V	-10 V	-10 V	-10 V	-10 V	-10 V	"	"	"	"	"	"	"	"	"	"	"	
		178	"	"	"		10 V	10 V	10 V	10 V	10 V	10 V	10 V	10 V	10 V	10 V	10 V	"	"	"	"	"	"	"	"	"	"	"	
																					Subgroup 12 T _A = 25°C								
																						Min	Max						
V _{ISO}		179	GND	GND	GND	0 V	IN	IN	IN	IN	IN	IN	IN	IN	IN	IN	IN	-15 V	OUT	OUT		50						dB	
V _{CT}		180	GND	GND	GND	5 V	6/	IN	IN	IN	IN	IN	IN	IN	IN	IN	IN	-15 V	OUT	OUT		50						dB	
V _{CTE}		181	IN	IN	IN	5 V	GND											-15 V	OUT	OUT			10					mV	
																						Subgroup 13 T _A = 25°C							
																						Min	Max						
t _d		182				5 V	10 V	10 V	10 V	10 V	10 V	10 V	10 V	10 V	10 V	10 V	10 V	-15 V	OUT	OUT		5						ns	
		183				"	-10 V	-10 V	-10 V	-10 V	-10 V	-10 V	-10 V	-10 V	-10 V	-10 V	-10 V	-10 V	"	"	"	"	"	"	"	"	"	"	"
		184				"	10 V	10 V	10 V	10 V	10 V	10 V	10 V	10 V	10 V	10 V	10 V	10 V	"	"	"	"	"	"	"	"	"	"	"
		185				"	-10 V	-10 V	-10 V	-10 V	-10 V	-10 V	-10 V	-10 V	-10 V	-10 V	-10 V	-10 V	"	"	"	"	"	"	"	"	"	"	"

See footnotes at end of table.

TABLE III. Group A inspection for device type 02.

Symbol	MIL-STD-883 method	Case X	Terminal conditions 1/														Measured Terminal	Test limits						Unit	
			1	2	3	4	5	6	7	8	9	10	11	12	13	14		Subgroup 1 T _A = 25°C		Subgroup 2 T _A = 125°C		Subgroup 3 T _A = -55°C			
			Test no.	V+	NC	NC	IN16	IN15	IN14	IN13	IN12	IN11	IN10	IN9	GND	V _{REF}		A3	Min	Max	Min	Max	Min		Max
V _{IC(POS)}		1	GND												GND		1 mA	A3		1.5					V
		2	"												"			A2		"					"
		3	"												"			A1		"					"
		4	"												"			A0		"					"
		5	"												"			EN		"					"
V _{IC(NEG)}		6															-1 mA	A3	-1.5						"
		7																A2	"						"
		8																A1	"						"
		9																A0	"						"
		10																EN	"						"
I _{IH} 2/	3010	11	15 V															A3	-0.1	1.0	-0.1	1.0	-0.1	1.0	μA
	"	12	"															A2	"	"	"	"	"	"	"
	"	13	"															A1	"	"	"	"	"	"	"
	"	14	"															A0	"	"	"	"	"	"	"
	"	15	"															EN	"	"	"	"	"	"	"
I _{IL} 2/	3009	16	"														0.8 V	A3	-1.0	0.1	-1.0	0.1	-1.0	0.1	"
	"	17	"														5 V	A2	"	"	"	"	"	"	"
	"	18	"															A1	"	"	"	"	"	"	"
	"	19	"															A0	"	"	"	"	"	"	"
	"	20	"															EN	"	"	"	"	"	"	"
I _{S(OFF)} 3/		21	"			-10 V	-10 V	-10 V	-10 V	-10 V	-10 V	-10 V	-10 V	"			0.8 V	IN1	-1	1	-50	50	-50	50	nA
		22	"			"	"	"	"	"	"	"	"	"	"			IN2	"	"	"	"	"	"	"
		23	"			"	"	"	"	"	"	"	"	"	"			IN3	"	"	"	"	"	"	"
		24	"			"	"	"	"	"	"	"	"	"	"			IN4	"	"	"	"	"	"	"
		25	"			"	"	"	"	"	"	"	"	"	"			IN5	"	"	"	"	"	"	"
		26	"			"	"	"	"	"	"	"	"	"	"			IN6	"	"	"	"	"	"	"
		27	"			"	"	"	"	"	"	"	"	"	"			IN7	"	"	"	"	"	"	"
		28	"			"	"	"	"	"	"	"	"	"	"			IN8	"	"	"	"	"	"	"
		29	"			"	"	"	"	"	"	"	"	10 V	"			IN9	"	"	"	"	"	"	"
		30	"			"	"	"	"	"	"	10 V	-10 V	"	"			IN10	"	"	"	"	"	"	"
		31	"			"	"	"	"	"	10 V	-10 V	"	"	"			IN11	"	"	"	"	"	"	"
		32	"			"	"	"	"	10 V	-10 V	"	"	"	"			IN12	"	"	"	"	"	"	"
		33	"			"	"	"	10 V	-10 V	"	"	"	"	"			IN13	"	"	"	"	"	"	"
		34	"			"	"	10 V	-10 V	"	"	"	"	"	"			IN14	"	"	"	"	"	"	"
		35	"			"	10 V	-10 V	-10 V	-10 V	"	"	"	"	"			IN15	"	"	"	"	"	"	"
		36	"			10 V	-10 V	-10 V	-10 V	"	"	"	"	"	"			IN16	"	"	"	"	"	"	"
		37	"			10 V	10 V	10 V	10 V	10 V	10 V	10 V	10 V	"	"		0.8 V	IN1	"	"	"	"	"	"	"
		38	"			"	"	"	"	"	"	"	"	"	"			IN2	"	"	"	"	"	"	"
		39	"			"	"	"	"	"	"	"	"	"	"			IN3	"	"	"	"	"	"	"
		40	"			"	"	"	"	"	"	"	"	"	"			IN4	"	"	"	"	"	"	"
	41	"			"	"	"	"	"	"	"	"	"	"			IN5	"	"	"	"	"	"	"	
	42	"			"	"	"	"	"	"	"	"	"	"			IN6	"	"	"	"	"	"	"	
	43	"			"	"	"	"	"	"	"	"	"	"			IN7	"	"	"	"	"	"	"	
	44	"			"	"	"	"	"	"	"	"	"	"			IN8	"	"	"	"	"	"	"	
	45	"			"	"	"	"	"	"	"	"	-10 V	"			IN9	"	"	"	"	"	"	"	
	46	"			"	"	"	"	"	"	"	-10 V	10 V	"			IN10	"	"	"	"	"	"	"	
	47	"			"	"	"	"	"	"	-10 V	10 V	"	"			IN11	"	"	"	"	"	"	"	
	48	"			"	"	"	"	"	-10 V	10 V	"	"	"			IN12	"	"	"	"	"	"	"	
	49	"			"	"	"	"	-10 V	10 V	10 V	"	"	"			IN13	"	"	"	"	"	"	"	
	50	"			"	"	"	-10 V	10 V	10 V	10 V	"	"	"			IN14	"	"	"	"	"	"	"	

See footnotes at end of table.

TABLE III. Group A inspection for device type 02 – Continued.

Symbol	Case X	Terminal conditions 1/														Measured Terminal	Test limits						Unit
		15	16	17	18	19	20	21	22	23	24	25	26	27	28		Subgroup 1 T _A = 25°C		Subgroup 2 T _A = 125°C		Subgroup 3 T _A = -55°C		
		Test no.	A2	A1	A0	EN	IN1	IN2	IN3	IN4	IN5	IN6	IN7	IN8	V-		OUT	Min	Max	Min	Max	Min	
V _{IC(POS)}	1	1 mA														A3		1.5					V
	2		1 mA													A2		"					"
	3			1 mA												A1		"					"
	4				1 mA											A0		"					"
	5															EN		"					"
V _{IC(NEG)}	6	-1 mA												GND		A3	-1.5						"
	7		-1 mA													A2		"					"
	8			-1 mA												A1		"					"
	9				-1 mA											A0		"					"
	10															EN		"					"
I _{IH} 2/	11	GND	GND	GND	15 V									-15 V		A3	-0.1	1.0	-0.1	1.0	-0.1	1.0	μA
	12	4.0 V	GND	GND	"											A2	"	"	"	"	"	"	"
	13	GND	4.0 V	GND	"											A1	"	"	"	"	"	"	"
	14	GND	GND	4.0 V	"											A0	"	"	"	"	"	"	"
	15	GND	GND	GND	4.0 V											EN	"	"	"	"	"	"	"
I _{IL} 2/	16	5 V	5 V	5 V	5 V											A3	-1.0	0.1	-1.0	0.1	-1.0	0.1	"
	17	0.8 V	5 V	5 V	"											A2	"	"	"	"	"	"	"
	18	5 V	0.8 V	5 V	"											A1	"	"	"	"	"	"	"
	19	5 V	5 V	0.8 V	"											A0	"	"	"	"	"	"	"
	20	5 V	5 V	5 V	0.8 V											EN	"	"	"	"	"	"	"
I _{SI(OFF)} 3/	21	0.8 V	0.8 V	0.8 V	"	10 V	-10 V	-10 V	-10 V	-10 V	-10 V	-10 V	-10 V	"	-10 V	IN1	-1	1	-50	50	-50	50	nA
	22	"	0.8 V	4.0 V	"	-10 V	10 V	-10 V	-10 V	"	"	"	"	"	"	IN2	"	"	"	"	"	"	"
	23	"	4.0 V	0.8 V	"	"	-10 V	10 V	-10 V	"	"	"	"	"	"	IN3	"	"	"	"	"	"	"
	24	"	4.0 V	4.0 V	"	"	"	-10 V	10 V	"	"	"	"	"	"	IN4	"	"	"	"	"	"	"
	25	4.0 V	0.8 V	0.8 V	"	"	"	"	-10 V	10 V	"	"	"	"	"	IN5	"	"	"	"	"	"	"
	26	"	0.8 V	4.0 V	"	"	"	"	"	-10 V	10 V	"	"	"	"	IN6	"	"	"	"	"	"	"
	27	"	4.0 V	0.8 V	"	"	"	"	"	"	-10 V	10 V	"	"	"	IN7	"	"	"	"	"	"	"
	28	"	4.0 V	4.0 V	"	"	"	"	"	"	"	-10 V	10 V	"	"	IN8	"	"	"	"	"	"	"
	29	0.8 V	0.8 V	0.8 V	"	"	"	"	"	"	"	"	-10 V	"	"	IN9	"	"	"	"	"	"	"
	30	"	0.8 V	4.0 V	"	"	"	"	"	"	"	"	"	"	"	IN10	"	"	"	"	"	"	"
	31	"	4.0 V	0.8 V	"	"	"	"	"	"	"	"	"	"	"	IN11	"	"	"	"	"	"	"
	32	"	4.0 V	4.0 V	"	"	"	"	"	"	"	"	"	"	"	IN12	"	"	"	"	"	"	"
	33	4.0 V	0.8 V	0.8 V	"	"	"	"	"	"	"	"	"	"	"	IN13	"	"	"	"	"	"	"
	34	"	0.8 V	4.0 V	"	"	"	"	"	"	"	"	"	"	"	IN14	"	"	"	"	"	"	"
	35	"	4.0 V	0.8 V	"	"	"	"	"	"	"	"	"	"	"	IN15	"	"	"	"	"	"	"
	36	"	4.0 V	4.0 V	"	"	"	"	"	"	"	"	"	"	"	IN16	"	"	"	"	"	"	"
	37	0.8 V	0.8 V	0.8 V	"	"	10 V	10 V	10 V	10 V	10 V	10 V	10 V	"	10 V	IN1	"	"	"	"	"	"	"
	38	"	0.8 V	4.0 V	"	10 V	-10 V	10 V	10 V	"	"	"	"	"	"	IN2	"	"	"	"	"	"	"
	39	"	4.0 V	0.8 V	"	"	10 V	-10 V	10 V	"	"	"	"	"	"	IN3	"	"	"	"	"	"	"
	40	"	4.0 V	4.0 V	"	"	"	10 V	-10 V	"	"	"	"	"	"	IN4	"	"	"	"	"	"	"
	41	4.0 V	0.8 V	0.8 V	"	"	"	"	10 V	-10 V	"	"	"	"	"	IN5	"	"	"	"	"	"	"
	42	"	0.8 V	4.0 V	"	"	"	"	"	10 V	-10 V	"	"	"	"	IN6	"	"	"	"	"	"	"
	43	"	4.0 V	0.8 V	"	"	"	"	"	"	10 V	-10 V	"	"	"	IN7	"	"	"	"	"	"	"
	44	"	4.0 V	4.0 V	"	"	"	"	"	"	"	10 V	-10 V	"	"	IN8	"	"	"	"	"	"	"
	45	0.8 V	0.8 V	0.8 V	"	"	"	"	"	"	"	"	10 V	"	"	IN9	"	"	"	"	"	"	"
	46	"	0.8 V	4.0 V	"	"	"	"	"	"	"	"	"	"	"	IN10	"	"	"	"	"	"	"
	47	"	4.0 V	0.8 V	"	"	"	"	"	"	"	"	"	"	"	IN11	"	"	"	"	"	"	"
	48	"	4.0 V	4.0 V	"	"	"	"	"	"	"	"	"	"	"	IN12	"	"	"	"	"	"	"
	49	4.0 V	0.8 V	0.8 V	"	"	"	"	"	"	"	"	"	"	"	IN13	"	"	"	"	"	"	"
	50	4.0 V	0.8 V	4.0 V	"	"	"	"	"	"	"	"	"	"	"	IN14	"	"	"	"	"	"	"

See footnotes at end of table.

TABLE III. Group A inspection for device type 02 – Continued.

Symbol	MIL-STD-883 method	Case X	Terminal conditions 1/														Measured Terminal	Test limits						Unit
			1	2	3	4	5	6	7	8	9	10	11	12	13	14		Subgroup 1 T _A = 25°C		Subgroup 2 T _A = 125°C		Subgroup 3 T _A = -55°C		
			Test no.	V+	NC	NC	IN16	IN15	IN14	IN13	IN12	IN11	IN10	IN9	GND	V _{REF}		A3	Min	Max	Min	Max	Min	
I _{S(OFF)} 3/		51	15 V			10 V	-10 V	10 V	10 V	10 V	10 V	10 V	10 V	GND		4.0 V	IN15	-1	1	-50	50	-50	50	nA
		52	"			-10 V	10 V	10 V	10 V	10 V	10 V	10 V	"	4.0 V	IN16	"	"	-50	50	"	"	"	"	
I _{D(OFF)}		53	"			10 V	10 V	10 V	10 V	10 V	10 V	10 V	"	0.8 V	OUT	-20	20	-500	500	-500	500	"	"	
		54	"			-10 V	-10 V	-10 V	-10 V	-10 V	-10 V	-10 V	"	"	OUT	"	"	"	"	"	"	"	"	
I _{D(ON)}		55	"			"	"	"	"	"	"	"	"	"	"	"	IN1 & OUT	"	"	"	"	"	"	
		56	"			"	"	"	"	"	"	"	"	"	"	"	IN2 & OUT	"	"	"	"	"	"	
		57	"			"	"	"	"	"	"	"	"	"	"	"	IN3 & OUT	"	"	"	"	"	"	
		58	"			"	"	"	"	"	"	"	"	"	"	"	IN4 & OUT	"	"	"	"	"	"	
		59	"			"	"	"	"	"	"	"	"	"	"	"	IN5 & OUT	"	"	"	"	"	"	
		60	"			"	"	"	"	"	"	"	"	"	"	"	IN6 & OUT	"	"	"	"	"	"	
		61	"			"	"	"	"	"	"	"	"	"	"	"	IN7 & OUT	"	"	"	"	"	"	
		62	"			"	"	"	"	"	"	"	"	"	"	"	IN8 & OUT	"	"	"	"	"	"	
		63	"			"	"	"	"	"	"	"	"	10 V	"	4.0 V	IN9 & OUT	"	"	"	"	"	"	
		64	"			"	"	"	"	"	"	"	10 V	-10 V	"	"	IN10 & OUT	"	"	"	"	"	"	
		65	"			"	"	"	"	"	"	10 V	-10 V	"	"	IN11 & OUT	"	"	"	"	"	"		
		66	"			"	"	"	"	"	10 V	-10 V	"	"	IN12 & OUT	"	"	"	"	"	"	"	"	
		67	"			"	"	"	"	10 V	-10 V	"	"	"	"	IN13 & OUT	"	"	"	"	"	"		
		68	"			"	"	10 V	-10 V	"	"	"	"	"	IN14 & OUT	"	"	"	"	"	"	"	"	
		69	"			"	10 V	-10 V	"	"	"	"	"	"	IN15 & OUT	"	"	"	"	"	"	"	"	
		70	"			10 V	-10 V	"	"	"	"	"	"	"	IN16 & OUT	"	"	"	"	"	"	"	"	
		71	"			-10 V	"	"	"	"	"	"	"	"	0.8 V	IN1 & OUT	"	"	"	"	"	"		
		72	"			"	"	"	"	"	"	"	"	"	"	"	IN2 & OUT	"	"	"	"	"	"	
		73	"			"	"	"	"	"	"	"	"	"	"	"	IN3 & OUT	"	"	"	"	"	"	
		74	"			"	"	"	"	"	"	"	"	"	"	"	IN4 & OUT	"	"	"	"	"	"	
		75	"			"	"	"	"	"	"	"	"	"	"	"	IN5 & OUT	"	"	"	"	"	"	
		76	"			10 V	10 V	10 V	10 V	10 V	10 V	10 V	10 V	"	"	IN6 & OUT	"	"	"	"	"	"	"	"
		77	"			"	"	"	"	"	"	"	"	10 V	"	"	IN7 & OUT	"	"	"	"	"	"	
		78	"			"	"	"	"	"	"	"	"	10 V	"	"	IN8 & OUT	"	"	"	"	"	"	
		79	"			"	"	"	"	"	"	"	"	-10 V	"	4.0 V	IN9 & OUT	"	"	"	"	"	"	
		80	"			"	"	"	"	"	"	"	-10 V	10 V	"	"	IN10 & OUT	"	"	"	"	"	"	
	81	"			"	"	"	"	"	"	-10 V	10 V	"	"	IN11 & OUT	"	"	"	"	"	"			
	82	"			"	"	"	"	"	-10 V	10 V	"	"	IN12 & OUT	"	"	"	"	"	"	"	"		
	83	"			"	"	"	"	-10 V	10 V	"	"	"	IN13 & OUT	"	"	"	"	"	"	"	"		
	84	"			"	"	"	-10 V	10 V	"	"	"	"	IN14 & OUT	"	"	"	"	"	"	"	"		
	85	"			"	-10 V	10 V	10 V	"	"	"	"	"	IN15 & OUT	"	"	"	"	"	"	"	"		
	86	"			-10 V	10 V	10 V	"	"	"	"	"	"	IN16 & OUT	"	"	"	"	"	"	"	"		
I+		87	"			"	"	"	"	"	"	"	"	0 V	V+		2.0		2.0		2.0	mA		
I-		88	"			"	"	"	"	"	"	"	"	"	V-		-1		-1		-1	"		
I+SBY		89	"			"	"	"	"	"	"	"	"	"	V+		2.0		2.0		2.0	"		
I-SBY		90	"			"	"	"	"	"	"	"	"	"	V-		-1.0		-1.0		-1.0	"		
I _{D+(OFF)} open voltage		91	"			"	"	"	"	"	"	"	"	0.8 V	OUT	-2.0	2.0	-2.0	2.0	-2.0	2.0	μA		
		92	"			"	"	"	"	"	"	"	"	"	"	"	"	"	"	"	"	"	"	
		93	"			"	"	"	"	"	"	"	"	"	"	"	"	"	"	"	"	"	"	
		94	"			"	"	"	"	"	"	"	"	"	"	"	"	"	"	"	"	"	"	
		95	"			"	"	"	"	"	"	"	"	"	"	"	"	"	"	"	"	"	"	
		96	"			"	"	"	"	"	"	"	"	"	"	"	"	"	"	"	"	"	"	
		97	"			"	"	"	"	"	"	"	"	"	"	"	"	"	"	"	"	"	"	
		98	"			"	"	"	"	"	"	"	"	"	"	"	"	"	"	"	"	"	"	
		99	"			"	"	"	"	"	"	33 V	"	"	4.0 V	"	"	"	"	"	"	"	"	
		100	"			"	"	"	"	"	33 V	"	"	4.0 V	"	"	"	"	"	"	"	"		

See footnotes at end of table.

TABLE III. Group A inspection for device type 02 – Continued.

Symbol	Case X	Terminal conditions 1/														Measured Terminal	Test limits						Unit	
		15	16	17	18	19	20	21	22	23	24	25	26	27	28		Subgroup 1 T _A = 25°C		Subgroup 2 T _A = 125°C		Subgroup 3 T _A = -55°C			
		Test no.	A2	A1	A0	EN	IN1	IN2	IN3	IN4	IN5	IN6	IN7	IN8	V-		OUT	Min	Max	Min	Max	Min		Max
I _{S(OFF)} 3/	51	4.0 V	4.0 V	0.8 V	0.8 V	10 V	10 V	10 V	10 V	10 V	10 V	10 V	10 V	-15 V	10 V	IN15	-1	1	-50	50	-50	50	nA	
	52	4.0 V	4.0 V	4.0 V	“	10 V	10 V	10 V	10 V	10 V	10 V	10 V	10 V	“	10 V	IN16	“	“	-50	50	“	“	“	
I _{D(OFF)}	53	0.8 V	0.8 V	0.8 V	“	10 V	10 V	10 V	10 V	10 V	10 V	10 V	10 V	“	-10 V	OUT	-20	20	-500	500	-500	500	“	
	54	“	“	0.8 V	“	-10 V	-10 V	-10 V	-10 V	-10 V	-10 V	-10 V	-10 V	“	10 V	OUT	“	“	“	“	“	“	“	“
I _{D(ON)}	55	“	“	0.8 V	4.0 V	10 V	-10 V	-10 V	-10 V	“	“	“	“	“	“	IN1 & OUT	“	“	“	“	“	“	“	“
	56	“	“	4.0 V	“	-10 V	10 V	-10 V	-10 V	“	“	“	“	“	“	IN2 & OUT	“	“	“	“	“	“	“	“
	57	“	4.0 V	0.8 V	“	“	-10 V	10 V	-10 V	“	“	“	“	“	“	IN3 & OUT	“	“	“	“	“	“	“	“
	58	“	4.0 V	4.0 V	“	“	“	-10 V	10 V	“	“	“	“	“	“	IN4 & OUT	“	“	“	“	“	“	“	“
	59	4.0 V	0.8 V	0.8 V	“	“	“	“	-10 V	10 V	“	“	“	“	“	IN5 & OUT	“	“	“	“	“	“	“	“
	60	“	0.8 V	4.0 V	“	“	“	“	“	-10 V	10 V	“	“	“	“	IN6 & OUT	“	“	“	“	“	“	“	“
	61	“	4.0 V	0.8 V	“	“	“	“	“	“	-10 V	10 V	“	“	“	IN7 & OUT	“	“	“	“	“	“	“	“
	62	“	4.0 V	4.0 V	“	“	“	“	“	“	“	-10 V	10 V	“	“	IN8 & OUT	“	“	“	“	“	“	“	“
	63	0.8 V	0.8 V	0.8 V	“	“	“	“	“	“	“	“	-10 V	“	“	IN9 & OUT	“	“	“	“	“	“	“	“
	64	“	0.8 V	4.0 V	“	“	“	“	“	“	“	“	“	“	“	IN10 & OUT	“	“	“	“	“	“	“	“
	65	“	4.0 V	0.8 V	“	“	“	“	“	“	“	“	“	“	“	IN11 & OUT	“	“	“	“	“	“	“	“
	66	“	4.0 V	4.0 V	“	“	“	“	“	“	“	“	“	“	“	IN12 & OUT	“	“	“	“	“	“	“	“
	67	4.0 V	0.8 V	0.8 V	“	“	“	“	“	“	“	“	“	“	“	IN13 & OUT	“	“	“	“	“	“	“	“
	68	“	0.8 V	4.0 V	“	“	“	“	“	“	“	“	“	“	“	IN14 & OUT	“	“	“	“	“	“	“	“
	69	“	4.0 V	0.8 V	“	“	“	“	“	“	“	“	“	“	“	IN15 & OUT	“	“	“	“	“	“	“	“
	70	“	4.0 V	4.0 V	“	“	“	“	“	“	“	“	“	“	“	IN16 & OUT	“	“	“	“	“	“	“	“
	71	0.8 V	0.8 V	0.8 V	“	“	10 V	10 V	10 V	10 V	10 V	10 V	10 V	“	-10 V	IN1 & OUT	“	“	“	“	“	“	“	“
	72	“	0.8 V	4.0 V	“	“	10 V	-10 V	10 V	10 V	“	“	“	“	“	IN2 & OUT	“	“	“	“	“	“	“	“
	73	“	4.0 V	0.8 V	“	“	10 V	-10 V	10 V	“	“	“	“	“	“	IN3 & OUT	“	“	“	“	“	“	“	“
	74	“	4.0 V	4.0 V	“	“	10 V	10 V	-10 V	“	“	“	“	“	“	IN4 & OUT	“	“	“	“	“	“	“	“
	75	4.0 V	0.8 V	0.8 V	“	“	10 V	10 V	10 V	-10 V	“	“	“	“	“	IN5 & OUT	“	“	“	“	“	“	“	“
	76	“	0.8 V	4.0 V	“	“	“	“	“	“	-10 V	“	“	“	“	IN6 & OUT	“	“	“	“	“	“	“	“
	77	“	4.0 V	0.8 V	“	“	“	“	“	“	“	“	-10 V	“	“	IN7 & OUT	“	“	“	“	“	“	“	“
	78	“	4.0 V	4.0 V	“	“	“	“	“	“	“	“	“	-10 V	“	IN8 & OUT	“	“	“	“	“	“	“	“
	79	0.8 V	0.8 V	0.8 V	“	“	“	“	“	“	“	“	“	“	“	IN9 & OUT	“	“	“	“	“	“	“	“
	80	“	0.8 V	4.0 V	“	“	“	“	“	“	“	“	“	“	“	IN10 & OUT	“	“	“	“	“	“	“	“
	81	“	4.0 V	0.8 V	“	“	“	“	“	“	“	“	“	“	“	IN11 & OUT	“	“	“	“	“	“	“	“
	82	“	4.0 V	4.0 V	“	“	“	“	“	“	“	“	“	“	“	IN12 & OUT	“	“	“	“	“	“	“	“
83	4.0 V	0.8 V	0.8 V	“	“	“	“	“	“	“	“	“	“	“	IN13 & OUT	“	“	“	“	“	“	“	“	
84	“	0.8 V	4.0 V	“	“	“	“	“	“	“	“	“	“	“	IN14 & OUT	“	“	“	“	“	“	“	“	
85	“	4.0 V	0.8 V	“	“	“	“	“	“	“	“	“	“	“	IN15 & OUT	“	“	“	“	“	“	“	“	
86	“	4.0 V	4.0 V	“	“	“	“	“	“	“	“	“	“	“	IN16 & OUT	“	“	“	“	“	“	“	“	
I+	87	0 V	0 V	0 V	5.0 V	“	“	“	“	“	“	“	“	“	V+	-1	2.0	-1	2.0	-1	2.0	“	mA	
I-	88	“	“	“	“	“	“	“	“	“	“	“	“	“	V-	“	“	“	“	“	“	“	“	
I+SBY	89	“	“	“	0 V	“	“	“	“	“	“	“	“	“	V+	-1	2.0	-1	2.0	-1	2.0	“	“	
I-SBY	90	“	“	“	“	“	“	“	“	“	“	“	“	“	V-	-1.0	2.0	-1.0	2.0	-1.0	2.0	“	“	
I _{D+(OFF)} over voltage	91	0.8 V	0.8 V	0.8 V	0.8 V	33 V	“	“	“	“	“	“	“	“	OUT	-2.0	2.0	-2.0	2.0	-2.0	2.0	“	μA	
	92	“	“	4.0 V	“	“	33 V	“	“	“	“	“	“	“	“	“	“	“	“	“	“	“	“	
	93	“	4.0 V	0.8 V	“	“	“	33 V	“	“	“	“	“	“	“	“	“	“	“	“	“	“	“	
	94	“	4.0 V	4.0 V	“	“	“	“	33 V	“	“	“	“	“	“	“	“	“	“	“	“	“	“	
	95	4.0 V	0.8 V	0.8 V	“	“	“	“	“	33 V	“	“	“	“	“	“	“	“	“	“	“	“	“	
	96	“	0.8 V	4.0 V	“	“	“	“	“	“	33 V	“	“	“	“	“	“	“	“	“	“	“	“	
	97	“	4.0 V	0.8 V	“	“	“	“	“	“	“	33 V	“	“	“	“	“	“	“	“	“	“	“	
	98	“	4.0 V	4.0 V	“	“	“	“	“	“	“	“	33 V	“	“	“	“	“	“	“	“	“	“	
	99	0.8 V	0.8 V	0.8 V	“	“	“	“	“	“	“	“	“	“	“	“	“	“	“	“	“	“	“	
	100	0.8 V	0.8 V	4.0 V	“	“	“	“	“	“	“	“	“	“	“	“	“	“	“	“	“	“	“	

See footnotes at end of table.

TABLE III. Group A inspection for device type 02 – Continued.

Symbol	MIL-STD-883 method	Case X	Terminal conditions 1/														Measured Terminal	Test limits						Unit			
			1	2	3	4	5	6	7	8	9	10	11	12	13	14		Subgroup 1 T _A = 25°C		Subgroup 2 T _A = 125°C		Subgroup 3 T _A = -55°C					
			Test no.	V+	NC	NC	IN16	IN15	IN14	IN13	IN12	IN11	IN10	IN9	GND	V _{REF}		A3	Min	Max	Min	Max	Min		Max		
I _{D+(OFF)} over-voltage	101	15 V												33 V			GND		4.0 V	OUT	-2.0	2.0	-2.0	2.0	-2.0	2.0	μA
	102	"												33 V			"		"	"	"	"	"	"	"	"	"
	103	"												33 V			"		"	"	"	"	"	"	"	"	"
	104	"												33 V			"		"	"	"	"	"	"	"	"	"
	105	"												33 V			"		"	"	"	"	"	"	"	"	"
	106	"												33 V			"		"	"	"	"	"	"	"	"	"
I _{D-(OFF)} over-voltage	107	"																	0.8 V	"	"	"	"	"	"	"	"
	108	"																	0.8 V	"	"	"	"	"	"	"	"
	109	"																	0.8 V	"	"	"	"	"	"	"	"
	110	"																	0.8 V	"	"	"	"	"	"	"	"
	111	"																	0.8 V	"	"	"	"	"	"	"	"
	112	"																	0.8 V	"	"	"	"	"	"	"	"
	113	"																	0.8 V	"	"	"	"	"	"	"	"
	114	"																	0.8 V	"	"	"	"	"	"	"	"
	115	"																	0.8 V	"	"	"	"	"	"	"	"
	116	"																	0.8 V	"	"	"	"	"	"	"	"
	117	"																	0.8 V	"	"	"	"	"	"	"	"
	118	"																	0.8 V	"	"	"	"	"	"	"	"
	119	"																	0.8 V	"	"	"	"	"	"	"	"
	120	"																	0.8 V	"	"	"	"	"	"	"	"
	121	"																	0.8 V	"	"	"	"	"	"	"	"
	122	"																	0.8 V	"	"	"	"	"	"	"	"
	R _{DS1}	123	"																	0.8 V	IN1 & OUT	1.5	"	"	"	1.5	kΩ
		124	"																	0.8 V	IN2 & OUT	"	"	"	"	"	"
125		"																	0.8 V	IN3 & OUT	"	"	"	"	"	"	
126		"																	0.8 V	IN4 & OUT	"	"	"	"	"	"	
127		"																	0.8 V	IN5 & OUT	"	"	"	"	"	"	
128		"																	0.8 V	IN6 & OUT	"	"	"	"	"	"	
129		"																	0.8 V	IN7 & OUT	"	"	"	"	"	"	
130		"																	0.8 V	IN8 & OUT	"	"	"	"	"	"	
131		"																	0.8 V	IN9 & OUT	"	"	"	"	"	"	
132		"																	0.8 V	IN10 & OUT	"	"	"	"	"	"	
133		"																	0.8 V	IN11 & OUT	"	"	"	"	"	"	
134		"																	0.8 V	IN12 & OUT	"	"	"	"	"	"	
135		"																	0.8 V	IN13 & OUT	"	"	"	"	"	"	
136		"																	0.8 V	IN14 & OUT	"	"	"	"	"	"	
137		"																	0.8 V	IN15 & OUT	"	"	"	"	"	"	
138		"																	0.8 V	IN16 & OUT	"	"	"	"	"	"	
139		"																	0.8 V	IN1 & OUT	"	"	"	"	"	"	
140		"																	0.8 V	IN2 & OUT	"	"	"	"	"	"	
141		"																	0.8 V	IN3 & OUT	"	"	"	"	"	"	
142		"																	0.8 V	IN4 & OUT	"	"	"	"	"	"	
143		"																	0.8 V	IN5 & OUT	"	"	"	"	"	"	
144		"																	0.8 V	IN6 & OUT	"	"	"	"	"	"	
145		"																	0.8 V	IN7 & OUT	"	"	"	"	"	"	
146		"																	0.8 V	IN8 & OUT	"	"	"	"	"	"	
147		"																	0.8 V	IN9 & OUT	"	"	"	"	"	"	
148		"																	0.8 V	IN10 & OUT	"	"	"	"	"	"	
149		"																	0.8 V	IN11 & OUT	"	"	"	"	"	"	
150		"																	0.8 V	IN12 & OUT	"	"	"	"	"	"	
151		"																	0.8 V	IN13 & OUT	"	"	"	"	"	"	
152		"																	0.8 V	IN14 & OUT	"	"	"	"	"	"	
153		"																	0.8 V	IN15 & OUT	"	"	"	"	"	"	
154		"																	0.8 V	IN16 & OUT	"	"	"	"	"	"	
R _{DS2}	155 thru 170	Same terminal conditions as tests 123 thru 138, except V _± = ±10 V, V _S = +7.5 V, and limits as shown.																			2.4		2.4		2.4	"	
R _{DS2}	171 thru 186	Same terminal conditions as tests 139 thru 154, except V _± = ±10 V, V _S = -7.5 V, and limits as shown.																			2.4		2.4		2.4	"	

See footnotes at end of table.

TABLE III. Group A inspection for device type 02 – Continued.

Symbol	Case X	Terminal conditions 1/														Measured Terminal	Test limits						Unit
		15	16	17	18	19	20	21	22	23	24	25	26	27	28		Subgroup 1 T _A = 25°C		Subgroup 2 T _A = 125°C		Subgroup 3 T _A = -55°C		
		Test no.	A2	A1	A0	EN	IN1	IN2	IN3	IN4	IN5	IN6	IN7	IN8	V-		OUT	Min	Max	Min	Max	Min	
I _{D+(OFF)} over-voltage	101	0.8 V	4.0 V	0.8 V	0.8 V										-15 V	OUT	-2.0	2.0	-2.0	2.0	-2.0	2.0	μA
	102	0.8 V	4.0 V	4.0 V	“										“	“	“	“	“	“	“	“	“
	103	4.0 V	0.8 V	0.8 V	“										“	“	“	“	“	“	“	“	“
	104	“	0.8 V	4.0 V	“										“	“	“	“	“	“	“	“	“
	105	“	4.0 V	0.8 V	“										“	“	“	“	“	“	“	“	“
	106	“	4.0 V	4.0 V	“										“	“	“	“	“	“	“	“	“
I _{D-(OFF)} over-voltage	107	0.8 V	0.8 V	0.8 V	“	-33 V									“	“	“	“	“	“	“	“	“
	108	“	0.8 V	4.0 V	“		-33 V								“	“	“	“	“	“	“	“	“
	109	“	4.0 V	0.8 V	“			-33 V							“	“	“	“	“	“	“	“	“
	110	“	4.0 V	4.0 V	“				-33 V						“	“	“	“	“	“	“	“	“
	111	4.0 V	0.8 V	0.8 V	“					-33 V					“	“	“	“	“	“	“	“	“
	112	“	0.8 V	4.0 V	“						-33 V				“	“	“	“	“	“	“	“	“
	113	“	4.0 V	0.8 V	“							-33 V			“	“	“	“	“	“	“	“	“
	114	“	4.0 V	4.0 V	“								-33 V		“	“	“	“	“	“	“	“	“
	115	0.8 V	0.8 V	0.8 V	“										“	“	“	“	“	“	“	“	“
	116	“	0.8 V	4.0 V	“										“	“	“	“	“	“	“	“	“
	117	“	4.0 V	0.8 V	“										“	“	“	“	“	“	“	“	“
	118	“	4.0 V	4.0 V	“										“	“	“	“	“	“	“	“	“
	119	4.0 V	0.8 V	0.8 V	“										“	“	“	“	“	“	“	“	“
	120	“	0.8 V	4.0 V	“										“	“	“	“	“	“	“	“	“
121	“	4.0 V	0.8 V	“										“	“	“	“	“	“	“	“	“	
122	“	4.0 V	4.0 V	“										“	“	“	“	“	“	“	“	“	
R _{DS1}	123	0.8 V	0.8 V	0.8 V	4.0 V	10 V									100 μA	IN1 & OUT	1.5	“	“	“	1.5	kΩ	
	124	“	0.8 V	4.0 V	“		10 V								“	IN2 & OUT	“	“	“	“	“	“	
	125	“	4.0 V	0.8 V	“			10 V							“	IN3 & OUT	“	“	“	“	“	“	
	126	“	4.0 V	4.0 V	“				10 V						“	IN4 & OUT	“	“	“	“	“	“	
	127	4.0 V	0.8 V	0.8 V	“					10 V					“	IN5 & OUT	“	“	“	“	“	“	
	128	“	0.8 V	4.0 V	“						10 V				“	IN6 & OUT	“	“	“	“	“	“	
	129	“	4.0 V	0.8 V	“							10 V			“	IN7 & OUT	“	“	“	“	“	“	
	130	“	4.0 V	4.0 V	“								10 V		“	IN8 & OUT	“	“	“	“	“	“	
	131	0.8 V	0.8 V	0.8 V	“										“	IN9 & OUT	“	“	“	“	“	“	
	132	“	0.8 V	4.0 V	“										“	IN10 & OUT	“	“	“	“	“	“	
	133	“	4.0 V	0.8 V	“										“	IN11 & OUT	“	“	“	“	“	“	
	134	“	4.0 V	4.0 V	“										“	IN12 & OUT	“	“	“	“	“	“	
	135	4.0 V	0.8 V	0.8 V	“										“	IN13 & OUT	“	“	“	“	“	“	
	136	“	0.8 V	4.0 V	“										“	IN14 & OUT	“	“	“	“	“	“	
	137	“	4.0 V	0.8 V	“										“	IN15 & OUT	“	“	“	“	“	“	
	138	“	4.0 V	4.0 V	“										“	IN16 & OUT	“	“	“	“	“	“	
	139	0.8 V	0.8 V	0.8 V	“	-10 V									“	-100 μA	IN1 & OUT	“	“	“	“	“	“
	140	“	0.8 V	4.0 V	“			-10 V							“	“	IN2 & OUT	“	“	“	“	“	“
	141	“	4.0 V	0.8 V	“				-10 V						“	“	IN3 & OUT	“	“	“	“	“	“
	142	“	4.0 V	4.0 V	“					-10 V					“	“	IN4 & OUT	“	“	“	“	“	“
	143	4.0 V	0.8 V	0.8 V	“						-10 V				“	“	IN5 & OUT	“	“	“	“	“	“
	144	“	0.8 V	4.0 V	“							-10 V			“	“	IN6 & OUT	“	“	“	“	“	“
	145	“	4.0 V	0.8 V	“								-10 V		“	“	IN7 & OUT	“	“	“	“	“	“
	146	“	4.0 V	4.0 V	“									-10 V	“	“	IN8 & OUT	“	“	“	“	“	“
	147	0.8 V	0.8 V	0.8 V	“										“	“	IN9 & OUT	“	“	“	“	“	“
	148	“	0.8 V	4.0 V	“										“	“	IN10 & OUT	“	“	“	“	“	“
	149	“	4.0 V	0.8 V	“										“	“	IN11 & OUT	“	“	“	“	“	“
	150	“	4.0 V	4.0 V	“										“	“	IN12 & OUT	“	“	“	“	“	“
151	4.0 V	0.8 V	0.8 V	“										“	“	IN13 & OUT	“	“	“	“	“	“	
152	“	0.8 V	4.0 V	“										“	“	IN14 & OUT	“	“	“	“	“	“	
153	“	4.0 V	0.8 V	“										“	“	IN15 & OUT	“	“	“	“	“	“	
154	“	4.0 V	4.0 V	“										“	“	IN16 & OUT	“	“	“	“	“	“	
R _{DS2}	155 thru 170	Same terminal conditions as tests 123 thru 138, except V _± = ±10 V, V _S = +7.5 V, and limits as shown.														2.4	2.4	2.4	2.4	“			
R _{DS2}	171 thru 186	Same terminal conditions as tests 139 thru 154, except V _± = ±10 V, V _S = -7.5 V, and limits as shown.														2.4	2.4	2.4	2.4	“			

See footnotes at end of table.

TABLE III. Group A inspection for device type 02 – Continued.

Symbol	MIL-STD-883 method	Case X	Terminal conditions 1/														Measured Terminal	Test limits						Unit				
			1	2	3	4	5	6	7	8	9	10	11	12	13	14		Subgroup 4 T _A = 25°C										
			Test no.	V+	NC	NC	IN16	IN15	IN14	IN13	IN12	IN11	IN10	IN9	GND	V _{REF}		A3	Min	Max								
C _A	3012	187	GND												GND	A3		10							pF			
	"	188	"												"	A2		"							"			
	"	189	"												"	A1		"							"			
	"	190	"												"	A0		"							"			
C _{OS}	"	191	"											"	OUT		85							"				
C _{IS}	"	192	"												"	IN1		10							"			
	"	193	"												"	IN2		"							"			
	"	194	"												"	IN3		"							"			
	"	195	"												"	IN4		"							"			
	"	196	"												"	IN5		"							"			
	"	197	"												"	IN6		"							"			
	"	198	"												"	IN7		"							"			
	"	199	"												"	IN8		"							"			
	"	200	"											4/	"	IN9		"							"			
	"	201	"												4/	IN10		"							"			
	"	202	"												4/	IN11		"							"			
	"	203	"											4/	"	IN12		"							"			
	"	204	"											4/	"	IN13		"							"			
	"	205	"											4/	"	IN14		"							"			
	"	206	"											4/	"	IN15		"							"			
	"	207	"											4/	"	IN16		"							"			
C _{EN}	"	208	"											"			"							"				
t _{ON(A)} and t _{OFF(A)}	3003 fig. 6	209	15 V			-10 V	GND	GND	GND	GND	GND	GND	GND	GND			ADDRESS IN TO OUT		1,000		1,500		1,000		ns			
		210	"			10 V	"	"	"	"	"	"	"	"	"		"	"	"	"	"	"	"	"	"			
		211	"			-10 V	"	"	"	"	"	"	"	"	"		"	"	"	"	"	"	"	"	"	"		
		212	"			10 V	"	"	"	"	"	"	"	"	"		"	"	"	"	"	"	"	"	"	"	"	
		213	"			GND	"	"	"	"	"	"	"	"	"		"	"	"	"	"	"	"	"	"	"	"	
		214	"			"	"	"	"	"	"	"	"	"	"		"	"	"	"	"	"	"	"	"	"	"	"
		215	"			"	"	"	"	"	"	"	"	"	"		"	"	"	"	"	"	"	"	"	"	"	"
216	"			"	"	"	"	"	"	"	"	"	"	"	"	"	"	"	"	"	"	"	"	"	"			
t _{ON(EN)} and t _{OFF(EN)}	fig. 7	217	"			-10 V	-10 V	-10 V	-10 V	-10 V	-10 V	-10 V	-10 V	"	GND	"	"	"	"	"	"	"	"	"	"			
		218	"			10 V	10 V	10 V	10 V	10 V	10 V	10 V	10 V	"	"	"	"	"	"	"	"	"	"	"	"			
		219	"			-10 V	-10 V	-10 V	-10 V	-10 V	-10 V	-10 V	-10 V	"	"	"	"	"	"	"	"	"	"	"	"	"		
		220	"			10 V	10 V	10 V	10 V	10 V	10 V	10 V	10 V	"	"	"	"	"	"	"	"	"	"	"	"	"		

See footnotes at end of table.

TABLE III. Group A inspection for device type 02 – Continued.

Symbol	MIL-STD-883 method	Case X	Terminal conditions 1/														Measured Terminal	Test limits						Unit				
			15	16	17	18	19	20	21	22	23	24	25	26	27	28		Subgroup 4 T _A = 25°C										
			Test no.	A2	A1	A0	EN	IN1	IN2	IN3	IN4	IN5	IN6	IN7	IN8	V-		OUT	Min	Max								
C _A		187															GND	A3	10					pF				
		188	4/															A2	"					"				
		189		4/														A1	"					"				
		190			4/													A0	"					"				
C _{OS}		191	0 V	0 V	0 V	0 V											"	5/	85					"				
C _{IS}		192	"	"	"	"	4/										"	"	10					"				
		193	"	"	"	"		4/									"	"	"					"				
		194	"	"	"	"			4/								"	"	"					"				
		195	"	"	"	"				4/							"	"	"					"				
		196	"	"	"	"					4/						"	"	"					"				
		197	"	"	"	"						4/					"	"	"					"				
		198	"	"	"	"							4/				"	"	"					"				
		199	"	"	"	"								4/			"	"	"					"				
		200	"	"	"	"									4/		"	"	"					"				
		201	"	"	"	"										0 V	"	"	"					"				
		202	"	"	"	"										"	"	"	"					"				
		203	"	"	"	"										"	"	"	"					"				
		204	"	"	"	"										"	"	"	"					"				
		205	"	"	"	"										"	"	"	"					"				
		206	"	"	"	"										"	"	"	"					"				
		207	"	"	"	"										"	"	"	"					"				
C _{EN}		208	"	"	"	4/										GND	EN	"	"					"				
																		Subgroup 9 T _A = 25°C		Subgroup 10 T _A = 125°C		Subgroup 11 T _A = -55°C						
t _{ON(A)} and t _{OFF(A)}		209				5 V	GND	GND	GND	GND	GND	GND	GND	GND	GND	-15 V	OUT	ADDRESS IN TO OUT	Min	1,000	Max	1,500	Min	1,000	Max	ns		
		210			"	"	"	"	"	"	"	"	"	"	"	"	"	"	"	"	"	"	"	"	"	"	"	"
		211			"	"	"	"	"	"	"	"	"	"	"	"	"	"	"	"	"	"	"	"	"	"	"	"
		212			"	"	"	"	"	"	"	"	"	"	"	"	"	"	"	"	"	"	"	"	"	"	"	
		213			"	"	"	"	"	"	"	"	"	"	"	"	"	"	"	"	"	"	"	"	"	"	"	
		214			"	"	"	"	"	"	"	"	"	"	"	"	"	"	"	"	"	"	"	"	"	"	"	
		215			"	"	"	"	"	"	"	"	"	"	"	"	"	"	"	"	"	"	"	"	"	"	"	
	216			"	"	"	"	"	"	"	"	"	"	"	"	"	"	"	"	"	"	"	"	"	"	"		
t _{ON(EN)} and t _{OFF(EN)}		217	GND	GND	GND	"	-10 V	-10 V	-10 V	-10 V	-10 V	-10 V	-10 V	-10 V	"	"	"	"	"	"	"	"	"	"	"	"		
		218	"	"	"	"	10 V	10 V	10 V	10 V	10 V	10 V	10 V	10 V	"	"	"	"	"	"	"	"	"	"	"	"		
		219	"	"	"	"	-10 V	-10 V	-10 V	-10 V	-10 V	-10 V	-10 V	-10 V	"	"	"	"	"	"	"	"	"	"	"	"		
		220	"	"	"	"	10 V	10 V	10 V	10 V	10 V	10 V	10 V	10 V	"	"	"	"	"	"	"	"	"	"	"	"		

See footnotes at end of table.

TABLE III. Group A inspection for device type 02 – Continued.

Symbol	MIL-STD-883 method	Case X	Terminal conditions 1/														Measured Terminal	Test limits				Unit			
			1	2	3	4	5	6	7	8	9	10	11	12	13	14		Subgroup 4 T _A = 25°C							
			Test no.	V+	NC	NC	IN16	IN15	IN14	IN13	IN12	IN11	IN10	IN9	GND	V _{REF}		A3	Min	Max					
V _{ISO}	fig. 15	221	15 V			IN	IN	IN	IN	IN	IN	IN	IN	GND		GND	OUT	50							dB
V _{CT}	fig. 16	222	15 V			IN	IN	IN	IN	IN	IN	IN	IN	GND		GND	OUT	50							dB
V _{CTE}	fig. 17	223	15 V											GND		IN	OUT		10						mV
																	Subgroup 13 T _A = 25°C								
																	Min	Max							
t _D	fig. 14	224	15 V			10 V	10 V	-10 V	10 V	10 V	10 V	10 V	10 V	GND			OUT	5							ns
	"	225	"			-10 V	-10 V	-10 V	-10 V	-10 V	-10 V	-10 V	-10 V	"			"	"							"
	"	226	"			10 V	10 V	10 V	10 V	10 V	10 V	10 V	10 V	"			"	"							"
	"	227	"			-10 V	-10 V	-10 V	-10 V	-10 V	-10 V	-10 V	-10 V	"			"	"							

See footnotes at end of table.

TABLE III. Group A inspection for device type 03.

Symbol	MIL-STD-883 method	Case X	Terminal conditions 1/														Measured Terminal	Test limits						Unit		
			1	2	3	4	5	6	7	8	9	10	11	12	13	14		Subgroup 1 T _A = 25°C		Subgroup 2 T _A = 125°C		Subgroup 3 T _A = -55°C				
			Test no.	V+	OUTB	NC	IN8B	IN7B	IN6B	IN5B	IN4B	IN3B	IN2B	IN1B	GND	NC		NC	Min	Max	Min	Max	Min		Max	
I _{IH} 2/	3010	1	15 V														GND	A2	-0.1	1.0	-0.1	1.0	-0.1	1.0	μA	
		2																	A1							
		3																	A0							
		4																	EN							
I _{IL} 2/	3009	5																A2	-1.0	0.1	-1.0	0.1	-1.0	0.1		
		6																A1								
		7																A0								
		8																EN								
I _{S(OFF)} 3/		9		-10 V		-10 V	-10 V	-10 V	-10 V	-10 V	-10 V	-10 V	10 V					IN1B	-1	1	-50	50	-50	50	nA	
		10																IN2B								
		11																IN3B								
		12																IN4B								
		13																IN5B								
		14																IN6B								
		15																IN7B								
		16																IN8B								
		17																IN1A								
		18																IN2A								
		19																IN3A								
		20																IN4A								
		21																IN5A								
		22																IN6A								
		23																IN7A								
		24																IN8A								
		25																IN1B								
		26																IN2B								
		27																IN3B								
		28																IN4B								
		29																IN5B								
		30																IN6B								
		31																IN7B								
		32																IN8B								
		33																IN1A								
		34																IN2A								
		35																IN3A								
		36																IN4A								
		37																IN5A								
		38																IN6A								
		39																IN7A								
		40																IN8A								
		I _{D(OFF)}		41															OUTA	-10	10	-250	250	-250	250	
				42															OUTA							
				43															OUTB							
				44															OUTB							
		I _{D(ON)}		45														IN1A & OUTA								
				46														IN2A & OUTA								
				47														IN3A & OUTA								
				48														IN4A & OUTA								
49																IN5A & OUTA										
50																IN6A & OUTA										

See footnotes at end of table.

TABLE III. Group A inspection for device type 03 – Continued.

Symbol	Case X	Terminal conditions <u>1/</u>															Measured Terminal	Test limits						Unit				
		15	16	17	18	19	20	21	22	23	24	25	26	27	28	Subgroup 1 T _A = 25°C		Subgroup 2 T _A = 125°C		Subgroup 3 T _A = -55°C								
		Test no.	A2	A1	A0	EN	IN1A	IN2A	IN3A	IN4A	IN5A	IN6A	IN7A	IN8A	V-	OUTA		Min	Max	Min	Max	Min	Max					
I _{IH} <u>2/</u>	1	2.4 V	GND	GND	5.0 V									-15 V		A2	-0.1	1.0	-0.1	1.0	-0.1	1.0	μA					
	2	GND	2.4 V	GND	5.0 V											A1												
	3	GND	GND	2.4 V	5.0 V											A0												
	4	GND	GND	GND	4.5 V											EN												
I _{IL} <u>2/</u>	5	0.8 V	5.0 V	5.0 V	5.0 V											A2	-1.0	0.1	-1.0	0.1	-1.0	0.1						
	6	5.0 V	0.8 V	5.0 V	5.0 V											A1												
	7	5.0 V	5.0 V	0.8 V	5.0 V											A0												
	8	5.0 V	5.0 V	5.0 V	0.8 V											EN												
I _{S(OFF)} <u>3/</u>	9	0.8 V	0.8 V	0.8 V	0.8 V	-10 V	-10 V	-10 V	-10 V	-10 V	-10 V	-10 V	-10 V	-10 V	-10 V	IN1B	-1	1	-50	50	-50	50	nA					
	10		0.8 V	2.4 V												IN2B												
	11		2.4 V	0.8 V												IN3B												
	12		2.4 V	2.4 V												IN4B												
	13	2.4 V	0.8 V	0.8 V												IN5B												
	14		0.8 V	2.4 V												IN6B												
	15		2.4 V	0.8 V												IN7B												
	16		2.4 V	2.4 V												IN8B												
	17	0.8 V	0.8 V	0.8 V		10 V										IN1A												
	18		0.8 V	2.4 V		-10 V	10 V									IN2A												
	19		2.4 V	0.8 V			-10 V	10 V								IN3A												
	20		2.4 V	2.4 V				-10 V	10 V							IN4A												
	21	2.4 V	0.8 V	0.8 V					-10 V	10 V						IN5A												
	22		0.8 V	2.4 V						-10 V	10 V					IN6A												
	23		2.4 V	0.8 V						-10 V	-10 V	10 V				IN7A												
	24		2.4 V	2.4 V						-10 V	-10 V	-10 V	10 V			IN8A												
	25	0.8 V	0.8 V	0.8 V		10 V	10 V	10 V	10 V	10 V	10 V	10 V	10 V		10 V	IN1B												
	26		0.8 V	2.4 V												IN2B												
	27		2.4 V	0.8 V												IN3B												
	28		2.4 V	2.4 V												IN4B												
	29	2.4 V	0.8 V	0.8 V												IN5B												
	30		0.8 V	2.4 V												IN6B												
	31		2.4 V	0.8 V												IN7B												
	32		2.4 V	2.4 V												IN8B												
	33	0.8 V	0.8 V	0.8 V		-10 V										IN1A												
	34		0.8 V	2.4 V		10 V	-10 V									IN2A												
	35		2.4 V	0.8 V			10 V	-10 V								IN3A												
	36		2.4 V	2.4 V				10 V	-10 V							IN4A												
	37	2.4 V	0.8 V	0.8 V					10 V	-10 V						IN5A												
	38		0.8 V	2.4 V						10 V	-10 V					IN6A												
	39		2.4 V	0.8 V							10 V	-10 V				IN7A												
	40		2.4 V	2.4 V								10 V	10 V	-10 V		IN8A												
	I _{D(OFF)}	41	0.8 V	0.8 V	0.8 V											10 V	10 V	10 V		-10 V	OUTA	-10	10	-250	250	-250	250	
		42					-10 V	-10 V	-10 V	-10 V	-10 V	-10 V	-10 V	-10 V	-10 V	10 V	OUTA											
		43					10 V	10 V	10 V	10 V	10 V	10 V	10 V	10 V	10 V	10 V	OUTB											
		44					-10 V	-10 V	-10 V	-10 V	-10 V	-10 V	-10 V	-10 V	-10 V	-10 V	OUTB											
	I _{D(ON)}	45				4.5 V	10 V	-10 V	-10 V	-10 V	-10 V					10 V	IN1A & OUTA											
		46			2.4 V		-10 V	10 V	-10 V	-10 V							IN2A & OUTA											
		47		2.4 V	0.8 V			-10 V	10 V	-10 V							IN3A & OUTA											
		48		2.4 V	2.4 V				-10 V	10 V							IN4A & OUTA											
49		2.4 V	0.8 V	0.8 V				-10 V	-10 V	10 V						IN5A & OUTA												
50		2.4 V	0.8 V	2.4 V				-10 V	-10 V	-10 V	10 V					IN6A & OUTA												

See footnotes at end of table.

TABLE III. Group A inspection for device type 03 – Continued.

Symbol	MIL-STD-883 method	Case X	Terminal conditions 1/														Measured Terminal	Test limits						Unit
			1	2	3	4	5	6	7	8	9	10	11	12	13	14		Subgroup 1 T _A = 25°C		Subgroup 2 T _A = 125°C		Subgroup 3 T _A = -55°C		
			Test no.	V+	OUTB	NC	IN8B	IN7B	IN6B	IN5B	IN4B	IN3B	IN2B	IN1B	GND	NC		NC	Min	Max	Min	Max	Min	
I _{D(ON)}		51	15 V	-10 V		-10 V	-10 V	-10 V	-10 V	-10 V	-10 V	-10 V	-10 V	GND			IN7A & OUTA	-10	10	-250	250	-250	250	nA
		52	"	-10 V		"	"	"	"	"	"	-10 V	-10 V	"			IN8A & OUTB	"	"	"	"	"	"	"
		53	"	10 V		"	"	"	"	"	"	-10 V	10 V	"			IN1B & OUTB	"	"	"	"	"	"	"
		54	"	"		"	"	"	"	"	"	10 V	-10 V	"			IN2B & OUTB	"	"	"	"	"	"	"
		55	"	"		"	"	"	"	"	"	10 V	-10 V	"			IN3B & OUTB	"	"	"	"	"	"	"
		56	"	"		"	"	"	"	"	"	10 V	-10 V	"			IN4B & OUTB	"	"	"	"	"	"	"
		57	"	"		"	"	"	"	"	"	10 V	-10 V	"			IN5B & OUTB	"	"	"	"	"	"	"
		58	"	"		"	"	"	"	"	"	10 V	-10 V	"			IN6B & OUTB	"	"	"	"	"	"	"
		59	"	"		"	"	"	"	"	"	10 V	-10 V	-10 V	"		IN7B & OUTB	"	"	"	"	"	"	"
		60	"	"		"	"	"	"	"	"	10 V	-10 V	-10 V	"		IN8B & OUTB	"	"	"	"	"	"	"
		61	"	"		"	"	"	"	"	"	10 V	10 V	10 V	10 V	10 V	IN1A & OUTA	"	"	"	"	"	"	"
		62	"	"		"	"	"	"	"	"	"	"	"	"	"	IN2A & OUTA	"	"	"	"	"	"	"
		63	"	"		"	"	"	"	"	"	"	"	"	"	"	IN3A & OUTA	"	"	"	"	"	"	"
		64	"	"		"	"	"	"	"	"	"	"	"	"	"	IN4A & OUTA	"	"	"	"	"	"	"
		65	"	"		"	"	"	"	"	"	"	"	"	"	"	IN5A & OUTA	"	"	"	"	"	"	"
		66	"	"		"	"	"	"	"	"	"	"	"	"	"	IN6A & OUTA	"	"	"	"	"	"	"
		67	"	"		"	"	"	"	"	"	"	"	"	"	"	IN7A & OUTA	"	"	"	"	"	"	"
		68	"	"		"	"	"	"	"	"	"	"	"	"	"	IN8A & OUTB	"	"	"	"	"	"	"
		69	"	-10 V		"	"	"	"	"	"	"	"	-10 V	"		IN1B & OUTB	"	"	"	"	"	"	"
		70	"	"		"	"	"	"	"	"	"	-10 V	10 V	"		IN2B & OUTB	"	"	"	"	"	"	"
		71	"	"		"	"	"	"	"	"	"	-10 V	10 V	"		IN3B & OUTB	"	"	"	"	"	"	"
		72	"	"		"	"	"	"	"	"	"	-10 V	10 V	"		IN4B & OUTB	"	"	"	"	"	"	"
		73	"	"		"	"	"	"	"	"	"	-10 V	10 V	"		IN5B & OUTB	"	"	"	"	"	"	"
		74	"	"		"	"	"	"	"	"	"	-10 V	10 V	"		IN6B & OUTB	"	"	"	"	"	"	"
		75	"	"		"	"	"	"	"	"	"	-10 V	10 V	"		IN7B & OUTB	"	"	"	"	"	"	"
		76	"	"		"	"	"	"	"	"	"	-10 V	10 V	"		IN8B & OUTB	"	"	"	"	"	"	"
I+		77	"													V+		14		14		14	mA	
I-		78	"													V-	-14		-14		-14		"	
I+SBY		79	"													V+		3.0		3.0		3.0	"	
I-SBY		80	"													V-	-4.0		-4.0		-4.0		"	
R _{DS1}		81	"													IN1A & OUTA		600		700		600	Ω	
		82	"											10 V		IN2A & OUTA		"		"		"	"	
		83	"											10 V		IN3A & OUTA		"		"		"	"	
		84	"											10 V		IN4A & OUTA		"		"		"	"	
		85	"											10 V		IN5A & OUTA		"		"		"	"	
		86	"											10 V		IN6A & OUTA		"		"		"	"	
		87	"											10 V		IN7A & OUTA		"		"		"	"	
		88	"											10 V		IN8A & OUTB		"		"		"	"	
		89	"	1 mA			10 V									IN1B & OUTB		"		"		"	"	
		90	"	"												IN2B & OUTB		"		"		"	"	
		91	"	"												IN3B & OUTB		"		"		"	"	
		92	"	"												IN4B & OUTB		"		"		"	"	
		93	"	"												IN5B & OUTB		"		"		"	"	
		94	"	"												IN6B & OUTB		"		"		"	"	
		95	"	"												IN7B & OUTB		"		"		"	"	
		96	"	"												IN8B & OUTB		"		"		"	"	
		97	"	"												IN1A & OUTA		"		"		"	"	
		98	"	"												IN2A & OUTA		"		"		"	"	
		99	"	"												IN3A & OUTA		"		"		"	"	
		100	"	"												IN4A & OUTA		"		"		"	"	

See footnotes at end of table.

TABLE III. Group A inspection for device type 03 – Continued.

Symbol	MIL-STD-883 method	Case X	Terminal conditions 1/														Measured Terminal	Test limits						Unit
			15	16	17	18	19	20	21	22	23	24	25	26	27	28		Subgroup 1 T _A = 25°C		Subgroup 2 T _A = 125°C		Subgroup 3 T _A = -55°C		
			Test no.	A2	A1	A0	EN	IN1A	IN2A	IN3A	IN4A	IN5A	IN6A	IN7A	IN8A	V-		OUTA	Min	Max	Min	Max	Min	
I _{D(ON)}		51	2.4 V	2.4 V	0.8 V	4.5 V	-10 V	-10 V	-10 V	-10 V	-10 V	-10 V	10 V	-10 V	-15 V	10 V	IN7A & OUTA	-10	10	-250	250	-250	250	nA
		52	2.4 V	2.4 V	2.4 V	"	"	"	"	"	"	"	"	"	10 V	10 V	IN8A & OUTB	"	"	"	"	"	"	"
		53	0.8 V	0.8 V	0.8 V	"	"	"	"	"	"	"	"	"	"	-10 V	IN1B & OUTB	"	"	"	"	"	"	"
		54	"	0.8 V	2.4 V	"	"	"	"	"	"	"	"	"	"	"	IN2B & OUTB	"	"	"	"	"	"	"
		55	"	2.4 V	0.8 V	"	"	"	"	"	"	"	"	"	"	"	IN3B & OUTB	"	"	"	"	"	"	"
		56	"	2.4 V	2.4 V	"	"	"	"	"	"	"	"	"	"	"	IN4B & OUTB	"	"	"	"	"	"	"
		57	2.4 V	0.8 V	0.8 V	"	"	"	"	"	"	"	"	"	"	"	IN5B & OUTB	"	"	"	"	"	"	"
		58	"	0.8 V	2.4 V	"	"	"	"	"	"	"	"	"	"	"	IN6B & OUTB	"	"	"	"	"	"	"
		59	"	2.4 V	0.8 V	"	"	"	"	"	"	"	"	"	"	"	IN7B & OUTB	"	"	"	"	"	"	"
		60	"	2.4 V	2.4 V	"	"	"	"	"	"	"	"	"	"	"	IN8B & OUTB	"	"	"	"	"	"	"
		61	0.8 V	0.8 V	0.8 V	"	-10 V	10 V	10 V	10 V	10 V	10 V	10 V	10 V	"	"	IN1A & OUTA	"	"	"	"	"	"	"
		62	"	0.8 V	2.4 V	"	10 V	-10 V	10 V	10 V	"	"	"	"	"	"	IN2A & OUTA	"	"	"	"	"	"	"
		63	"	2.4 V	0.8 V	"	"	10 V	-10 V	10 V	"	"	"	"	"	"	IN3A & OUTA	"	"	"	"	"	"	"
		64	"	2.4 V	2.4 V	"	"	"	10 V	-10 V	"	"	"	"	"	"	IN4A & OUTA	"	"	"	"	"	"	"
		65	2.4 V	0.8 V	0.8 V	"	"	"	"	10 V	-10 V	"	"	"	"	"	IN5A & OUTA	"	"	"	"	"	"	"
		66	"	0.8 V	2.4 V	"	"	"	"	"	10 V	-10 V	"	"	"	"	IN6A & OUTA	"	"	"	"	"	"	"
		67	"	2.4 V	0.8 V	"	"	"	"	"	"	10 V	-10 V	"	"	"	IN7A & OUTA	"	"	"	"	"	"	"
		68	"	2.4 V	2.4 V	"	"	"	"	"	"	"	10 V	-10 V	"	"	IN8A & OUTB	"	"	"	"	"	"	"
		69	0.8 V	0.8 V	0.8 V	"	"	"	"	"	"	"	"	10 V	10 V	"	IN1B & OUTB	"	"	"	"	"	"	"
		70	"	0.8 V	2.4 V	"	"	"	"	"	"	"	"	"	"	"	IN2B & OUTB	"	"	"	"	"	"	"
	71	"	2.4 V	0.8 V	"	"	"	"	"	"	"	"	"	"	"	IN3B & OUTB	"	"	"	"	"	"	"	
	72	"	2.4 V	2.4 V	"	"	"	"	"	"	"	"	"	"	"	IN4B & OUTB	"	"	"	"	"	"	"	
	73	2.4 V	0.8 V	0.8 V	"	"	"	"	"	"	"	"	"	"	"	IN5B & OUTB	"	"	"	"	"	"	"	
	74	"	0.8 V	2.4 V	"	"	"	"	"	"	"	"	"	"	"	IN6B & OUTB	"	"	"	"	"	"	"	
	75	"	2.4 V	0.8 V	"	"	"	"	"	"	"	"	"	"	"	IN7B & OUTB	"	"	"	"	"	"	"	
	76	"	2.4 V	2.4 V	"	"	"	"	"	"	"	"	"	"	"	IN8B & OUTB	"	"	"	"	"	"	"	
I+		77	0 V	0 V	0 V	5.0 V									"	V+		14		14		14	mA	
I-		78	"	"	"	5.0 V									"	V-		-14		-14		-14	"	
I+SBY		79	"	"	"	0 V									"	V+		3.0		3.0		3.0	"	
I-SBY		80	"	"	"	0 V									"	V-		-4.0		-4.0		-4.0	"	
R _{DS1}		81	0.8 V	0.8 V	0.8 V	4.5 V	10 V								1 mA	IN1A & OUTA		600		700		600	Ω	
		82	"	"	2.4 V	"		10 V							"	IN2A & OUTA		"		"		"	"	
		83	"	2.4 V	0.8 V	"			10 V						"	IN3A & OUTA		"		"		"	"	
		84	"	2.4 V	2.4 V	"				10 V					"	IN4A & OUTA		"		"		"	"	
		85	2.4 V	0.8 V	0.8 V	"					10 V				"	IN5A & OUTA		"		"		"	"	
		86	"	0.8 V	2.4 V	"						10 V			"	IN6A & OUTA		"		"		"	"	
		87	"	2.4 V	0.8 V	"							10 V		"	IN7A & OUTA		"		"		"	"	
		88	"	2.4 V	2.4 V	"								10 V	"	IN8A & OUTA		"		"		"	"	
		89	0.8 V	0.8 V	0.8 V	"									"	IN1B & OUTB		"		"		"	"	
		90	"	0.8 V	2.4 V	"									"	IN2B & OUTB		"		"		"	"	
		91	"	2.4 V	0.8 V	"									"	IN3B & OUTB		"		"		"	"	
		92	"	2.4 V	2.4 V	"									"	IN4B & OUTB		"		"		"	"	
		93	2.4 V	0.8 V	0.8 V	"									"	IN5B & OUTB		"		"		"	"	
		94	"	0.8 V	2.4 V	"									"	IN6B & OUTB		"		"		"	"	
		95	"	2.4 V	0.8 V	"									"	IN7B & OUTB		"		"		"	"	
		96	"	2.4 V	2.4 V	"									"	IN8B & OUTB		"		"		"	"	
		97	0.8 V	0.8 V	0.8 V	"	-10 V								"	-1 mA	IN1A & OUTA		"		"		"	"
		98	"	0.8 V	2.4 V	"			-10 V						"	"	IN2A & OUTA		"		"		"	"
		99	"	2.4 V	0.8 V	"				-10 V					"	"	IN3A & OUTA		"		"		"	"
		100	"	2.4 V	2.4 V	"					-10 V				"	"	IN4A & OUTA		"		"		"	"

See footnotes at end of table.

TABLE III. Group A inspection for device type 03 – Continued.

Symbol	MIL-STD-883 method	Case X	Terminal conditions 1/														Measured Terminal	Test limits						Unit
			1	2	3	4	5	6	7	8	9	10	11	12	13	14		Subgroup 1 T _A = 25°C		Subgroup 2 T _A = 125°C		Subgroup 3 T _A = -55°C		
			Test no.	V+	OUTB	NC	IN8B	IN7B	IN6B	IN5B	IN4B	IN3B	IN2B	IN1B	GND	NC		NC	Min	Max	Min	Max	Min	
R _{DS1}		101	15 V														IN5A & OUTA	600		700		600	Ω	
		102	"														IN6A & OUTA	"		"		"	"	
		103	"														IN7A & OUTA	"		"		"	"	
		104	"														IN8A & OUTB	"		"		"	"	
		105	"	-1 mA		-10 V											IN1B & OUTB	"		"		"	"	
		106	"	"			-10 V										IN2B & OUTB	"		"		"	"	
		107	"	"				-10 V									IN3B & OUTB	"		"		"	"	
		108	"	"					-10 V								IN4B & OUTB	"		"		"	"	
		109	"	"						-10 V							IN5B & OUTB	"		"		"	"	
		110	"	"							-10 V						IN6B & OUTB	"		"		"	"	
		111	"	"								-10 V					IN7B & OUTB	"		"		"	"	
		112	"	"									-10 V				IN8B & OUTB	"		"		"	"	
R _{DS2}		113 thru 128 – Same terminal conditions as for tests 81 thru 96, except V _± = ±10 V, V _S = +7.5 V, and limits as shown.															1.0		1.0		1.0	kΩ		
R _{DS2}		129 thru 144 – Same terminal conditions as for tests 97 thru 112, except V _± = ±10 V, V _S = -7.5 V, and limits as shown.															1.0		1.0		1.0	kΩ		
																		Subgroup 4 T _A = 25°C						
																		Min	Max					
C _A	3012	145	GND											GND			A2	10					pF	
	"	146	"											"			A1	10					"	
	"	147	"											"			A0	10					"	
C _{OS}	"	148	"											"			OUTA	50					"	
	"	149	"	5/										"			OUTB	50					"	
C _{IS}	"	150	"											"			IN1A	10					"	
	"	151	"											"			IN2A	"					"	
	"	152	"											"			IN3A	"					"	
	"	153	"											"			IN4A	"					"	
	"	154	"											"			IN5A	"					"	
	"	155	"											"			IN6A	"					"	
	"	156	"											"			IN7A	"					"	
	"	157	"											"			IN8A	"					"	
	"	158	"											"	4/		IN1B	"					"	
	"	159	"											"		4/	IN2B	"					"	
	"	160	"											"		4/	IN3B	"					"	
	"	161	"											"	4/		IN4B	"					"	
	"	162	"											"		4/	IN5B	"					"	
	"	163	"											"	4/		IN6B	"					"	
"	164	"											"		4/	IN7B	"					"		
"	165	"											"			IN8B	"					"		
C _{EN}	"	166	"											"		EN	"						"	

See footnotes at end of table.

TABLE III. Group A inspection for device type 03 – Continued.

Symbol	MIL-STD-883 method	Case X	Terminal conditions 1/														Measured Terminal	Test limits						Unit				
			15	16	17	18	19	20	21	22	23	24	25	26	27	28		Subgroup 1 T _A = 25°C		Subgroup 2 T _A = 125°C		Subgroup 3 T _A = -55°C						
			Test no.	A2	A1	A0	EN	IN1A	IN2A	IN3A	IN4A	IN5A	IN6A	IN7A	IN8A	V-		OUTA	Min	Max	Min	Max	Min		Max			
R _{DS1}	101	2.4 V	0.8 V	0.8 V	2.4 V									-10 V				-15 V	-1 mA	IN5A & OUTA		600		700		600	Ω	
	102	"	0.8 V	2.4 V	"									-10 V				"	"	IN6A & OUTA		"		"		"	"	
	103	"	2.4 V	0.8 V	"										-10 V			"	"	IN7A & OUTA		"		"		"	"	
	104	"	2.4 V	2.4 V	"													-10 V	"	"	IN8A & OUTB		"		"		"	"
	105	0.8 V	0.8 V	0.8 V	"													"	"	IN1B & OUTB		"		"		"	"	
	106	"	0.8 V	2.4 V	"													"	"	IN2B & OUTB		"		"		"	"	
	107	"	2.4 V	0.8 V	"													"	"	IN3B & OUTB		"		"		"	"	
	108	"	2.4 V	2.4 V	"													"	"	IN4B & OUTB		"		"		"	"	
	109	2.4 V	0.8 V	0.8 V	"													"	"	IN5B & OUTB		"		"		"	"	
	110	"	0.8 V	2.4 V	"													"	"	IN6B & OUTB		"		"		"	"	
	111	"	2.4 V	0.8 V	"													"	"	IN7B & OUTB		"		"		"	"	
	112	"	2.4 V	2.4 V	"													"	"	IN8B & OUTB		"		"		"	"	
R _{DS2}	113 thru 128 – Same terminal conditions as for tests 81 thru 96, except V _± = ±10 V, V _S = +7.5 V, and limits as shown.																					1.0		1.0		1.0	kΩ	
R _{DS2}	129 thru 144 – Same terminal conditions as for tests 97 thru 112, except V _± = ±10 V, V _S = -7.5 V, and limits as shown.																					1.0		1.0		1.0	kΩ	
																					Subgroup 4 T _A = 25°C							
																					Min	Max						
C _A	145	4/																GND		A2		10					pF	
	146		4/															"		A1		10					"	
	147			4/														"		A0		10					"	
C _{OS}	148	0 V	0 V	0 V	0 V													"	5/	OUTA		50					"	
	149	"	"	"	"													"		OUTB		50					"	
C _{IS}	150	"	"	"	"		4/											"	"	IN1A		10					"	
	151	"	"	"	"			4/										"	"	IN2A		"					"	
	152	"	"	"	"				4/									"	"	IN3A		"					"	
	153	"	"	"	"					4/								"	"	IN4A		"					"	
	154	"	"	"	"						4/							"	"	IN5A		"					"	
	155	"	"	"	"							4/						"	"	IN6A		"					"	
	156	"	"	"	"								4/					"	"	IN7A		"					"	
	157	"	"	"	"									4/				"	"	IN8A		"					"	
	158	"	"	"	"													"	"	IN1B		"					"	
	159	"	"	"	"													"	"	IN2B		"					"	
	160	"	"	"	"													"	"	IN3B		"					"	
	161	"	"	"	"													"	"	IN4B		"					"	
	162	"	"	"	"													"	"	IN5B		"					"	
	163	"	"	"	"													"	"	IN6B		"					"	
164	"	"	"	"													"	"	IN7B		"					"		
165	"	"	"	"													"	"	IN8B		"					"		
C _{EN}	166				4/													"	"	EN		"					"	

See footnotes at end of table.

TABLE III. Group A inspection for device type 03 – Continued.

Symbol	MIL-STD-883 method	Case X	Terminal conditions 1/														Measured Terminal	Test limits						Unit			
			1	2	3	4	5	6	7	8	9	10	11	12	13	14		Subgroup 9 T _A = 25°C		Subgroup 10 T _A = 125°C		Subgroup 11 T _A = -55°C					
			Test no.	V+	OUTB	NC	IN8B	IN7B	IN6B	IN5B	IN4B	IN3B	IN2B	IN1B	GND	NC		NC	Min	Max	Min	Max	Min		Max		
t _{ON(A)} and t _{OFF(A)}	3003 fig. 8	167	15 V			GND	GND	GND	GND	GND	GND	GND	GND	GND	GND	GND	ADDRESS IN TO OUTA		1,000		1,500		1,000	ns			
		168	"	"	"	"	"	"	"	"	"	"	"	"	"	"	"	"	"	"	"	"	"	"	"		
		169	"	"	"	"	"	"	"	"	"	"	"	"	"	"	"	"	"	"	"	"	"	"	"	"	
		170	"	"	"	"	"	"	"	"	"	"	"	"	"	"	"	"	"	"	"	"	"	"	"	"	
		171	"	"	"	"	"	"	"	"	"	"	"	"	"	"	"	"	"	"	"	"	"	"	"	"	
		172	"	"	"	"	"	"	"	"	"	"	"	"	"	"	"	"	"	"	"	"	"	"	"	"	
		173	"	"	"	"	"	"	"	"	"	"	"	"	"	"	"	"	"	"	"	"	"	"	"	"	
		174	"	"	"	"	"	"	"	"	"	"	"	"	"	"	"	"	"	"	"	"	"	"	"	"	
		175	"	"	OUT		10 V	"	"	"	"	"	"	"	"	"	"	"	ADDRESS IN TO OUTB	"	"	"	"	"	"	"	"
		176	"	"	"		-10 V	"	"	"	"	"	"	"	"	"	"	"	"	"	"	"	"	"	"	"	"
		177	"	"	"		10 V	"	"	"	"	"	"	"	"	"	"	"	"	"	"	"	"	"	"	"	"
		178	"	"	"		-10 V	"	"	"	"	"	"	"	"	"	"	"	"	"	"	"	"	"	"	"	"
		179	"	"	"		GND	"	"	"	"	"	"	"	10 V	"	"	"	"	"	"	"	"	"	"	"	"
		180	"	"	"		"	"	"	"	"	"	"	"	-10 V	"	"	"	"	"	"	"	"	"	"	"	"
181	"	"	"		"	"	"	"	"	"	"	"	10 V	"	"	"	"	"	"	"	"	"	"	"	"		
182	"	"	"		"	"	"	"	"	"	"	"	-10 V	"	"	"	"	"	"	"	"	"	"	"	"		
t _{ON(EN)} and t _{OFF(EN)}	3003 fig. 9	183	"			"	"	"	"	"	"	GND	GND	GND	GND	"	ENABLE TO OUTA	"	"	"	"	"	"	"	"		
		184	"	"	"	"	"	"	"	"	"	"	"	"	"	"	"	"	"	"	"	"	"	"	"	"	
		185	"	"	"	"	"	"	"	"	"	"	"	"	"	"	"	"	"	"	"	"	"	"	"	"	
		186	"	"	"	"	"	"	"	"	"	"	"	"	"	"	"	"	"	"	"	"	"	"	"	"	"
		187	"	"	OUT		-10 V	-10 V	-10 V	-10 V	-10 V	-10 V	-10 V	-10 V	-10 V	"	"	ENABLE TO OUTB	"	"	"	"	"	"	"	"	"
		188	"	"	"		10 V	10 V	10 V	10 V	10 V	10 V	10 V	10 V	10 V	"	"	"	"	"	"	"	"	"	"	"	"
		189	"	"	"		-10 V	-10 V	-10 V	-10 V	-10 V	-10 V	-10 V	-10 V	-10 V	"	"	"	"	"	"	"	"	"	"	"	"
190	"	"	"		10 V	10 V	10 V	10 V	10 V	10 V	10 V	10 V	10 V	"	"	"	"	"	"	"	"	"	"	"	"		
																		Subgroup 12 T _A = 25°C									
																		Min	Max								
V _{ISO}	fig. 15	191	15 V			IN	IN	IN	IN	IN	IN	IN	IN	GND			OUTA	50							dB		
	fig. 15	192	"	OUT		"	"	"	"	"	"	"	"	"	"	"	"	OUTB	"	"	"	"	"	"	"	"	
V _{CT}	fig. 16	193	"	OUT		"	"	"	"	"	"	"	"	"	"	"	OUTA	"	"	"	"	"	"	"	"		
	fig. 16	194	"	OUT		"	"	"	"	"	"	"	"	"	"	"	OUTB	"	"	"	"	"	"	"	"		
V _{CTE}	fig. 17	195	"											GND	"	"	OUTA		10						mV		
	fig. 17	196	"	OUT		"	"	"	"	"	"	"	"	GND	"	"	OUTB	"	10	"	"	"	"	"	mV		
																		Subgroup 13 T _A = 25°C									
																		Min	Max								
t _D	fig. 14	197	15 V			GND	GND	GND	GND	GND	GND	GND	GND	GND	GND	GND	OUTA	5							ns		
	"	198	"	"	"	"	"	"	"	"	"	"	"	"	"	"	"	"	"	"	"	"	"	"	"	"	
	"	199	"	"	"	"	"	"	"	"	"	"	"	"	"	"	"	"	"	"	"	"	"	"	"	"	
	"	200	"	"	"	"	"	"	"	"	"	"	"	"	"	"	"	"	"	"	"	"	"	"	"	"	
	"	201	"	"	OUT		10 V	10 V	10 V	10 V	10 V	10 V	10 V	10 V	10 V	"	"	OUTB	"	"	"	"	"	"	"	"	
	"	202	"	"	"		-10 V	-10 V	-10 V	-10 V	-10 V	-10 V	-10 V	-10 V	-10 V	"	"	"	"	"	"	"	"	"	"	"	"
	"	203	"	"	"		10 V	10 V	10 V	10 V	10 V	10 V	10 V	10 V	10 V	"	"	"	"	"	"	"	"	"	"	"	
	"	204	"	"	"		-10 V	-10 V	-10 V	-10 V	-10 V	-10 V	-10 V	-10 V	-10 V	"	"	"	"	"	"	"	"	"	"	"	"

See footnotes at end of table.

TABLE III. Group A inspection for device type 03 – Continued.

Symbol	MIL-STD-883 method	Case X	Terminal conditions 1/														Measured Terminal	Test limits						Unit
			15	16	17	18	19	20	21	22	23	24	25	26	27	28		Subgroup 9 T _A = 25°C		Subgroup 10 T _A = 125°C		Subgroup 11 T _A = -55°C		
			Test no.	A2	A1	A0	EN	IN1A	IN2A	IN3A	IN4A	IN5A	IN6A	IN7A	IN8A	V-		OUTA	Min	Max	Min	Max	Min	
t _{ON(A)} and t _{OFF(A)}		167				5 V	GND	GND	GND	GND	GND	GND	GND	-10 V	-15	OUT	ADDRESS IN TO OUTA		1,000		1,500		1,000	ns
		168				"	"	"	"	"	"	"	"	10 V	"	"	"	"	"	"	"	"	"	"
		169				"	"	"	"	"	"	"	"	-10 V	"	"	"	"	"	"	"	"	"	"
		170				"	"	"	"	"	"	"	"	10 V	"	"	"	"	"	"	"	"	"	"
		171				"	10 V	"	"	"	"	"	"	GND	"	"	"	"	"	"	"	"	"	"
		172				"	-10 V	"	"	"	"	"	"	"	"	"	"	"	"	"	"	"	"	"
		173				"	10 V	"	"	"	"	"	"	"	"	"	"	"	"	"	"	"	"	"
		174				"	-10 V	"	"	"	"	"	"	"	"	"	"	"	"	"	"	"	"	"
		175				"	GND	"	"	"	"	"	"	"	"	"	ADDRESS IN TO OUTB	"	"	"	"	"	"	"
		176				"	"	"	"	"	"	"	"	"	"	"	"	"	"	"	"	"	"	"
		177				"	"	"	"	"	"	"	"	"	"	"	"	"	"	"	"	"	"	"
		178				"	"	"	"	"	"	"	"	"	"	"	"	"	"	"	"	"	"	"
	179				"	"	"	"	"	"	"	"	"	"	"	"	"	"	"	"	"	"	"	
	180				"	"	"	"	"	"	"	"	"	"	"	"	"	"	"	"	"	"	"	
	181				"	"	"	"	"	"	"	"	"	"	"	"	"	"	"	"	"	"	"	
	182				"	"	"	"	"	"	"	"	"	"	"	"	"	"	"	"	"	"	"	
t _{ON(EN)} and t _{OFF(EN)}		183	GND	GND	GND		-10 V	-10 V	-10 V	-10 V	-10 V	-10 V	-10 V	-10 V	"	OUT	ENABLE TO OUTA	"	"	"	"	"	"	"
		184	"	"	"		10 V	10 V	10 V	10 V	10 V	10 V	10 V	10 V	"	"	"	"	"	"	"	"	"	"
		185	"	"	"		-10 V	-10 V	-10 V	-10 V	-10 V	-10 V	-10 V	-10 V	"	"	"	"	"	"	"	"	"	"
		186	"	"	"		10 V	10 V	10 V	10 V	10 V	10 V	10 V	10 V	"	"	"	"	"	"	"	"	"	"
		187	"	"	"		GND	GND	GND	GND	GND	GND	GND	GND	"	"	ENABLE TO OUTB	"	"	"	"	"	"	"
		188	"	"	"		"	"	"	"	"	"	"	"	"	"	"	"	"	"	"	"	"	"
		189	"	"	"		"	"	"	"	"	"	"	"	"	"	"	"	"	"	"	"	"	"
	190	"	"	"		"	"	"	"	"	"	"	"	"	"	"	"	"	"	"	"	"	"	
																	Subgroup 12 T _A = 25°C							
																	Min	Max						
V _{ISO}		191	GND	GND	GND	0 V	IN	IN	IN	IN	IN	IN	IN	IN	-15 V	OUT	OUTA	50						dB
		192	"	"	"	0 V	"	"	"	"	"	"	"	"	"	"	OUTB	"	"	"	"	"	"	"
V _{CT}		193	"	"	"	5 V	6/	"	"	"	"	"	"	"	"	"	OUT	OUTA	"	"	"	"	"	"
		194	"	"	"	"	6/	"	"	"	"	"	"	"	"	"	"	OUTB	"	"	"	"	"	"
V _{CTE}		195	IN	IN	IN	"	GND								"	OUT	OUTA		10					mV
		196	IN	IN	IN	"	GND								"	"	OUTB		10					mV
																	Subgroup 13 T _A = 25°C							
																	Min	Max						
t _D		197				5 V	10 V	10 V	10 V	10 V	10 V	10 V	10 V	10 V	-15 V	OUT	OUTA	5						ns
		198				"	-10 V	-10 V	-10 V	-10 V	-10 V	-10 V	-10 V	-10 V	"	"	"	"	"	"	"	"	"	"
		199				"	10 V	10 V	10 V	10 V	10 V	10 V	10 V	10 V	"	"	"	"	"	"	"	"	"	"
		200				"	-10 V	-10 V	-10 V	-10 V	-10 V	-10 V	-10 V	-10 V	"	"	"	"	"	"	"	"	"	"
		201				"	GND	GND	GND	GND	GND	GND	GND	GND	"	"	OUTB	"	"	"	"	"	"	"
		202				"	"	"	"	"	"	"	"	"	"	"	"	"	"	"	"	"	"	"
		203				"	"	"	"	"	"	"	"	"	"	"	"	"	"	"	"	"	"	"
	204				"	"	"	"	"	"	"	"	"	"	"	"	"	"	"	"	"	"	"	

See footnotes at end of table.

TABLE III. Group A inspection for device type 04.

Symbol	MIL-STD-883 method	Case X	Terminal conditions 1/														Measured Terminal	Test limits						Unit
			1	2	3	4	5	6	7	8	9	10	11	12	13	14		Subgroup 1 T _A = 25°C		Subgroup 2 T _A = 125°C		Subgroup 3 T _A = -55°C		
			Test no.	V+	OUTB	NC	IN8B	IN7B	IN6B	IN5B	IN4B	IN3B	IN2B	IN1B	GND	V _{REF}		NC	Min	Max	Min	Max	Min	
V _{IC(POS)}		1	GND												GND	A2		1.5					V	
		2	"												"	A1		"					"	
		3	"												"	A0		"					"	
		4	"												"	EN		"					"	
V _{IC(NEG)}		5	"												"	A2	-1.5						"	
		6	"												"	A1	"						"	
		7	"												"	A0	"						"	
		8	"												"	EN	"						"	
I _{IH} 2/	3010	9	15 V													A2	-0.1	1.0	-0.1	1.0	-0.1	1.0	μA	
	"	10	"												"	A1	"	"	"	"	"	"	"	
	"	11	"												"	A0	"	"	"	"	"	"	"	
	"	12	"												"	EN	"	"	"	"	"	"	"	
I _{IL} 2/	3009	13	"													A2	-1.0	0.1	-1.0	0.1	-1.0	0.1	"	
	"	14	"												"	A1	"	"	"	"	"	"	"	
	"	15	"												"	A0	"	"	"	"	"	"	"	
	"	16	"												"	EN	"	"	"	"	"	"	"	
I _{S(OFF)} 3/		17	"			-10 V	-10 V	-10 V	-10 V	-10 V	-10 V	-10 V	"		"	IN1A	-1	1	-50	50	-50	50	nA	
		18	"			"	"	"	"	"	"	"	"	"	"	IN2A	"	"	"	"	"	"	"	
		19	"			"	"	"	"	"	"	"	"	"	"	IN3A	"	"	"	"	"	"	"	
		20	"			"	"	"	"	"	"	"	"	"	"	IN4A	"	"	"	"	"	"	"	
		21	"			"	"	"	"	"	"	"	"	"	"	IN5A	"	"	"	"	"	"	"	
		22	"			"	"	"	"	"	"	"	"	"	"	IN6A	"	"	"	"	"	"	"	
		23	"			"	"	"	"	"	"	"	"	"	"	IN7A	"	"	"	"	"	"	"	
		24	"			"	"	"	"	"	"	"	"	"	"	IN8A	"	"	"	"	"	"	"	
		25	"			"	"	"	"	"	"	"	"	10 V	"	IN1B	"	"	"	"	"	"	"	
		26	"	-10 V			"	"	"	"	"	"	"	10 V	-10 V	IN2B	"	"	"	"	"	"	"	
		27	"	"			"	"	"	"	"	"	"	10 V	-10 V	IN3B	"	"	"	"	"	"	"	
		28	"	"			"	"	"	"	"	"	"	10 V	-10 V	IN4B	"	"	"	"	"	"	"	
		29	"	"			"	"	"	"	"	"	"	10 V	-10 V	IN5B	"	"	"	"	"	"	"	
		30	"	"			"	"	"	"	"	"	"	10 V	-10 V	IN6B	"	"	"	"	"	"	"	
		31	"	"			"	"	"	"	"	"	"	10 V	-10 V	IN7B	"	"	"	"	"	"	"	
		32	"	"			"	"	"	"	"	"	"	10 V	-10 V	IN8B	"	"	"	"	"	"	"	
		33	"	10 V			"	"	"	"	"	"	"	10 V	10 V	IN1A	"	"	"	"	"	"	"	
		34	"	"			"	"	"	"	"	"	"	10 V	10 V	IN2A	"	"	"	"	"	"	"	
		35	"	"			"	"	"	"	"	"	"	10 V	10 V	IN3A	"	"	"	"	"	"	"	
		36	"	"			"	"	"	"	"	"	"	10 V	10 V	IN4A	"	"	"	"	"	"	"	
		37	"	"			"	"	"	"	"	"	"	10 V	10 V	IN5A	"	"	"	"	"	"	"	
		38	"	"			"	"	"	"	"	"	"	10 V	10 V	IN6A	"	"	"	"	"	"	"	
		39	"	"			"	"	"	"	"	"	"	10 V	10 V	IN7A	"	"	"	"	"	"	"	
		40	"	"			"	"	"	"	"	"	"	10 V	10 V	IN8A	"	"	"	"	"	"	"	
		41	"	"			"	"	"	"	"	"	"	-10 V	10 V	IN1B	"	"	"	"	"	"	"	
		42	"	"			"	"	"	"	"	"	"	-10 V	10 V	IN2B	"	"	"	"	"	"	"	
		43	"	"			"	"	"	"	"	"	"	-10 V	10 V	IN3B	"	"	"	"	"	"	"	
		44	"	"			"	"	"	"	"	"	"	-10 V	10 V	IN4B	"	"	"	"	"	"	"	
	45	"	"			"	"	"	"	"	"	"	-10 V	10 V	IN5B	"	"	"	"	"	"	"		
	46	"	"			"	"	"	"	"	"	"	-10 V	10 V	IN6B	"	"	"	"	"	"	"		
	47	"	"			"	"	"	"	"	"	"	10 V	10 V	IN7B	"	"	"	"	"	"	"		
	48	"	"			"	"	"	"	"	"	"	10 V	10 V	IN8B	"	"	"	"	"	"	"		

See footnotes at end of table.

TABLE III. Group A inspection for device type 04 – Continued.

Symbol	Case X	Terminal conditions 1/														Measured Terminal	Test limits						Unit
		15	16	17	18	19	20	21	22	23	24	25	26	27	28		Subgroup 1 T _A = 25°C		Subgroup 2 T _A = 125°C		Subgroup 3 T _A = -55°C		
		Test no.	A2	A1	A0	EN	IN1A	IN2A	IN3A	IN4A	IN5A	IN6A	IN7A	IN8A	V-		OUTA	Min	Max	Min	Max	Min	
V _{IC(POS)}	1	1 mA														A2		1.5					V
	2		1 mA													A1							"
	3			1 mA												A0							"
	4				1 mA											EN							"
V _{IC(NEG)}	5	-1 mA													GND	A2	-1.5						"
	6		-1 mA													A1							"
	7			-1 mA												A0							"
	8				-1 mA											EN							"
I _{IH} 2/	9	4.0 V	GND	GND	5 V										-15 V	A2	-0.1	1.0	-0.1	1.0	-0.1	1.0	μA
	10	GND	4.0 V	GND	5 V											A1							"
	11	GND	GND	4.0 V	5 V											A0							"
	12	GND	GND	GND	4.0 V											EN							"
I _{IL} 2/	13	0.8 V	5 V	5 V	5 V											A2	-1.0	0.1	-1.0	0.1	-1.0	0.1	"
	14	5 V	0.8 V	5 V	5 V											A1							"
	15	5 V	5 V	0.8 V	5 V											A0							"
	16	5 V	5 V	5 V	0.8 V											EN							"
I _{S(OFF)} 3/	17	0.8 V	0.8 V	0.8 V	0.8 V	10 V	-10 V	-10 V	-10 V	-10 V	-10 V	-10 V	-10 V		-10 V	IN1A	-1	1	-50	50	-50	50	nA
	18	"	0.8 V	4.0 V	"	-10 V	10 V	-10 V	-10 V	"	"	"	"	"	"	IN2A	"	"	"	"	"	"	"
	19	"	4.0 V	0.8 V	"	"	-10 V	10 V	-10 V	"	"	"	"	"	"	IN3A	"	"	"	"	"	"	"
	20	"	4.0 V	4.0 V	"	"	-10 V	10 V	10 V	"	"	"	"	"	"	IN4A	"	"	"	"	"	"	"
	21	4.0 V	0.8 V	0.8 V	"	"	"	"	-10 V	10 V	"	"	"	"	"	IN5A	"	"	"	"	"	"	"
	22	"	0.8 V	4.0 V	"	"	"	"	-10 V	10 V	"	"	"	"	"	IN6A	"	"	"	"	"	"	"
	23	"	4.0 V	0.8 V	"	"	"	"	"	-10 V	10 V	"	"	"	"	IN7A	"	"	"	"	"	"	"
	24	"	4.0 V	4.0 V	"	"	"	"	"	"	-10 V	10 V	"	"	"	IN8A	"	"	"	"	"	"	"
	25	0.8 V	0.8 V	0.8 V	"	"	"	"	"	"	-10 V	"	"	"	"	IN1B	"	"	"	"	"	"	"
	26	"	0.8 V	4.0 V	"	"	"	"	"	"	"	"	"	"	"	IN2B	"	"	"	"	"	"	"
	27	"	4.0 V	0.8 V	"	"	"	"	"	"	"	"	"	"	"	IN3B	"	"	"	"	"	"	"
	28	"	4.0 V	4.0 V	"	"	"	"	"	"	"	"	"	"	"	IN4B	"	"	"	"	"	"	"
	29	4.0 V	0.8 V	0.8 V	"	"	"	"	"	"	"	"	"	"	"	IN5B	"	"	"	"	"	"	"
	30	"	0.8 V	4.0 V	"	"	"	"	"	"	"	"	"	"	"	IN6B	"	"	"	"	"	"	"
	31	"	4.0 V	0.8 V	"	"	"	"	"	"	"	"	"	"	"	IN7B	"	"	"	"	"	"	"
	32	"	4.0 V	4.0 V	"	"	"	"	"	"	"	"	"	"	"	IN8B	"	"	"	"	"	"	"
	33	0.8 V	0.8 V	0.8 V	"	"	10 V	10 V	10 V	10 V	10 V	10 V	10 V	"	10 V	IN1A	"	"	"	"	"	"	"
	34	"	0.8 V	4.0 V	"	10 V	-10 V	10 V	10 V	"	"	"	"	"	"	IN2A	"	"	"	"	"	"	"
	35	"	4.0 V	0.8 V	"	"	10 V	-10 V	10 V	"	"	"	"	"	"	IN3A	"	"	"	"	"	"	"
	36	"	4.0 V	4.0 V	"	"	10 V	-10 V	10 V	"	"	"	"	"	"	IN4A	"	"	"	"	"	"	"
	37	4.0 V	0.8 V	0.8 V	"	"	"	"	10 V	-10 V	"	"	"	"	"	IN5A	"	"	"	"	"	"	"
	38	"	0.8 V	4.0 V	"	"	"	"	10 V	-10 V	"	"	"	"	"	IN6A	"	"	"	"	"	"	"
	39	"	4.0 V	0.8 V	"	"	"	"	10 V	-10 V	"	"	"	"	"	IN7A	"	"	"	"	"	"	"
	40	"	4.0 V	4.0 V	"	"	"	"	"	10 V	-10 V	"	"	"	"	IN8A	"	"	"	"	"	"	"
	41	0.8 V	0.8 V	0.8 V	"	"	"	"	"	"	10 V	"	"	"	"	IN1B	"	"	"	"	"	"	"
	42	"	0.8 V	4.0 V	"	"	"	"	"	"	"	"	"	"	"	IN2B	"	"	"	"	"	"	"
	43	"	4.0 V	0.8 V	"	"	"	"	"	"	"	"	"	"	"	IN3B	"	"	"	"	"	"	"
	44	"	4.0 V	4.0 V	"	"	"	"	"	"	"	"	"	"	"	IN4B	"	"	"	"	"	"	"
	45	4.0 V	0.8 V	0.8 V	"	"	"	"	"	"	"	"	"	"	"	IN5B	"	"	"	"	"	"	"
	46	"	0.8 V	4.0 V	"	"	"	"	"	"	"	"	"	"	"	IN6B	"	"	"	"	"	"	"
	47	"	4.0 V	0.8 V	"	"	"	"	"	"	"	"	"	"	"	IN7B	"	"	"	"	"	"	"
	48	"	4.0 V	4.0 V	"	"	"	"	"	"	"	"	"	"	"	IN8B	"	"	"	"	"	"	"

TABLE III. Group A inspection for device type 04 – Continued.

Symbol	MIL-STD-883 method	Case X	Terminal conditions 1/														Measured Terminal	Test limits						Unit		
			1	2	3	4	5	6	7	8	9	10	11	12	13	14		Subgroup 1 T _A = 25°C		Subgroup 2 T _A = 125°C		Subgroup 3 T _A = -55°C				
			Test no.	V+	OUTB	NC	IN8B	IN7B	IN6B	IN5B	IN4B	IN3B	IN2B	IN1B	GND	V _{REF}		NC	Min	Max	Min	Max	Min		Max	
I _{D(OFF)}		49	15 V	-10 V		-10 V	-10 V	-10 V	-10 V	-10 V	-10 V	-10 V	-10 V	GND			OUTA	-10	10	-250	250	-250	250	nA		
		50		10 V		10 V	10 V	10 V	10 V	10 V	10 V	10 V	10 V				OUTA									
		51		10 V		-10 V	-10 V	-10 V	-10 V	-10 V	-10 V	-10 V	-10 V				OUTB									
		52		-10 V		10 V	10 V	10 V	10 V	10 V	10 V	10 V	10 V				OUTB									
I _{D(ON)}		53				-10 V	-10 V	-10 V	-10 V	-10 V	-10 V	-10 V					IN1A & OUTA									
		54															IN2A & OUTA									
		55															IN3A & OUTA									
		56															IN4A & OUTA									
		57															IN5A & OUTA									
		58															IN6A & OUTA									
		59															IN7A & OUTA									
		60															IN8A & OUTA									
		61		10 V										10 V			IN1B & OUTB									
		62											10 V	-10 V			IN2B & OUTB									
		63											10 V	-10 V			IN3B & OUTB									
		64											10 V	-10 V			IN4B & OUTB									
		65											10 V	-10 V			IN5B & OUTB									
		66											10 V	-10 V			IN6B & OUTB									
		67											10 V	-10 V	-10 V		IN7B & OUTB									
		68											10 V	-10 V	-10 V		IN8B & OUTB									
		69											10 V	10 V	10 V	10 V	IN1A & OUTA									
		70											10 V	10 V	10 V	10 V	IN2A & OUTA									
		71											10 V	10 V	10 V	10 V	IN3A & OUTA									
		72											10 V	10 V	10 V	10 V	IN4A & OUTA									
		73											10 V	10 V	10 V	10 V	IN5A & OUTA									
		74											10 V	10 V	10 V	10 V	IN6A & OUTA									
		75											10 V	10 V	10 V	10 V	IN7A & OUTA									
		76											10 V	10 V	10 V	10 V	IN8A & OUTA									
	77		-10 V											-10 V		IN1B & OUTB										
	78												-10 V	10 V		IN2B & OUTB										
	79												-10 V	10 V		IN3B & OUTB										
	80												-10 V	10 V		IN4B & OUTB										
	81												-10 V	10 V		IN5B & OUTB										
	82												-10 V	10 V		IN6B & OUTB										
	83												-10 V	10 V		IN7B & OUTB										
	84												-10 V	10 V		IN8B & OUTB										
I _{D+(OFF)} over-voltage		85															OUTA	-2.0	2.0	-2.0	2.0	-2.0	2.0	μA		
		86																								
		87																								
		88																								
		89																								
		90																								
		91																								
		92																								
		93			0 V													OUTB								
		94												33 V												
		95												33 V												
		96												33 V												
		97												33 V												
		98												33 V												
		99												33 V												
		100												33 V												

See footnotes at end of table.

TABLE III. Group A inspection for device type 04 – Continued.

Symbol	Case X	Terminal conditions 1/														Measured Terminal	Test limits						Unit	
		15	16	17	18	19	20	21	22	23	24	25	26	27	28		Subgroup 1 T _A = 25°C		Subgroup 2 T _A = 125°C		Subgroup 3 T _A = -55°C			
		Test no.	A2	A1	A0	EN	IN1A	IN2A	IN3A	IN4A	IN5A	IN6A	IN7A	IN8A	V-		OUTA	Min	Max	Min	Max	Min		Max
I _{D(OFF)}	49	0.8 V	0.8 V	0.8 V	0.8 V	-10 V	-10 V	-10 V	-10 V	-10 V	-10 V	-10 V	-10 V	-10 V	-15 V	10 V	OUTA	-10	10	-250	250	-250	250	nA
	50	"	"	"	"	10 V	10 V	10 V	10 V	10 V	10 V	10 V	10 V	"	-10 V	OUTA	"	"	"	"	"	"	"	"
	51	"	"	"	"	-10 V	-10 V	-10 V	-10 V	-10 V	-10 V	-10 V	-10 V	"	-10 V	OUTB	"	"	"	"	"	"	"	"
	52	"	"	"	"	10 V	10 V	10 V	10 V	10 V	10 V	10 V	10 V	"	10 V	OUTB	"	"	"	"	"	"	"	"
	53	"	"	"	4.0 V	10 V	-10 V	-10 V	-10 V	-10 V	-10 V	-10 V	-10 V	"	"	IN1A & OUTA	"	"	"	"	"	"	"	"
I _{D(ON)}	54	"	"	4.0 V	"	-10 V	10 V	-10 V	-10 V	"	"	"	"	"	"	IN2A & OUTA	"	"	"	"	"	"	"	
	55	"	4.0 V	0.8 V	"	"	-10 V	10 V	-10 V	"	"	"	"	"	"	IN3A & OUTA	"	"	"	"	"	"	"	
	56	"	4.0 V	4.0 V	"	"	"	-10 V	10 V	"	"	"	"	"	"	IN4A & OUTA	"	"	"	"	"	"	"	
	57	4.0 V	0.8 V	0.8 V	"	"	"	"	-10 V	10 V	"	"	"	"	"	IN5A & OUTA	"	"	"	"	"	"	"	
	58	"	0.8 V	4.0 V	"	"	"	"	"	-10 V	10 V	"	"	"	"	IN6A & OUTA	"	"	"	"	"	"	"	
	59	"	4.0 V	0.8 V	"	"	"	"	"	"	-10 V	10 V	"	"	"	IN7A & OUTA	"	"	"	"	"	"	"	
	60	"	4.0 V	4.0 V	"	"	"	"	"	"	"	-10 V	10 V	"	"	IN8A & OUTA	"	"	"	"	"	"	"	
	61	0.8 V	0.8 V	0.8 V	"	"	"	"	"	"	"	"	-10 V	-10 V	"	-10 V	IN1B & OUTB	"	"	"	"	"	"	"
	62	"	0.8 V	4.0 V	"	"	"	"	"	"	"	"	"	"	"	IN2B & OUTB	"	"	"	"	"	"	"	"
	63	"	4.0 V	0.8 V	"	"	"	"	"	"	"	"	"	"	"	IN3B & OUTB	"	"	"	"	"	"	"	"
	64	"	4.0 V	4.0 V	"	"	"	"	"	"	"	"	"	"	"	IN4B & OUTB	"	"	"	"	"	"	"	"
	65	4.0 V	0.8 V	0.8 V	"	"	"	"	"	"	"	"	"	"	"	IN5B & OUTB	"	"	"	"	"	"	"	"
	66	"	0.8 V	4.0 V	"	"	"	"	"	"	"	"	"	"	"	IN6B & OUTB	"	"	"	"	"	"	"	"
	67	"	4.0 V	0.8 V	"	"	"	"	"	"	"	"	"	"	"	IN7B & OUTB	"	"	"	"	"	"	"	"
	68	"	4.0 V	4.0 V	"	"	"	"	"	"	"	"	"	"	"	IN8B & OUTB	"	"	"	"	"	"	"	"
	69	0.8 V	0.8 V	0.8 V	"	"	10 V	10 V	10 V	10 V	10 V	10 V	10 V	"	"	IN1A & OUTA	"	"	"	"	"	"	"	"
	70	"	0.8 V	4.0 V	"	10 V	-10 V	10 V	10 V	"	"	"	"	"	"	IN2A & OUTA	"	"	"	"	"	"	"	"
	71	"	4.0 V	0.8 V	"	"	10 V	-10 V	10 V	"	"	"	"	"	"	IN3A & OUTA	"	"	"	"	"	"	"	"
	72	"	4.0 V	4.0 V	"	"	"	10 V	-10 V	"	"	"	"	"	"	IN4A & OUTA	"	"	"	"	"	"	"	"
	73	4.0 V	0.8 V	0.8 V	"	"	"	"	10 V	-10 V	"	"	"	"	"	IN5A & OUTA	"	"	"	"	"	"	"	"
	74	"	0.8 V	4.0 V	"	"	"	"	"	10 V	-10 V	"	"	"	"	IN6A & OUTA	"	"	"	"	"	"	"	"
	75	"	4.0 V	0.8 V	"	"	"	"	"	"	10 V	-10 V	"	"	"	IN7A & OUTA	"	"	"	"	"	"	"	"
	76	"	4.0 V	4.0 V	"	"	"	"	"	"	"	10 V	-10 V	"	"	IN8A & OUTA	"	"	"	"	"	"	"	"
	77	0.8 V	0.8 V	0.8 V	"	"	"	"	"	"	"	"	10 V	10 V	"	IN1B & OUTB	"	"	"	"	"	"	"	"
	78	"	0.8 V	4.0 V	"	"	"	"	"	"	"	"	"	"	"	IN2B & OUTB	"	"	"	"	"	"	"	"
	79	"	4.0 V	0.8 V	"	"	"	"	"	"	"	"	"	"	"	IN3B & OUTB	"	"	"	"	"	"	"	"
	80	"	4.0 V	4.0 V	"	"	"	"	"	"	"	"	"	"	"	IN4B & OUTB	"	"	"	"	"	"	"	"
	81	4.0 V	0.8 V	0.8 V	"	"	"	"	"	"	"	"	"	"	"	IN5B & OUTB	"	"	"	"	"	"	"	"
	82	"	0.8 V	4.0 V	"	"	"	"	"	"	"	"	"	"	"	IN6B & OUTB	"	"	"	"	"	"	"	"
	83	"	4.0 V	0.8 V	"	"	"	"	"	"	"	"	"	"	"	IN7B & OUTB	"	"	"	"	"	"	"	"
	84	"	4.0 V	4.0 V	"	"	"	"	"	"	"	"	"	"	"	IN8B & OUTB	"	"	"	"	"	"	"	"
	I _{D+(OFF)} over-voltage	85	0.8 V	0.8 V	0.8 V	0.8 V	33 V	"	"	"	"	"	"	"	"	0 V	OUTA	-2.0	2.0	-2.0	2.0	-2.0	2.0	μA
86		"	0.8 V	4.0 V	"	"	33 V	"	"	"	"	"	"	"	"	"	"	"	"	"	"	"	"	"
87		"	0.8 V	4.0 V	0.8 V	"	"	33 V	"	"	"	"	"	"	"	"	"	"	"	"	"	"	"	"
88		"	4.0 V	4.0 V	"	"	"	"	33 V	"	"	"	"	"	"	"	"	"	"	"	"	"	"	"
89		4.0 V	0.8 V	0.8 V	"	"	"	"	"	33 V	"	"	"	"	"	"	"	"	"	"	"	"	"	"
90		"	0.8 V	4.0 V	"	"	"	"	"	"	33 V	"	"	"	"	"	"	"	"	"	"	"	"	"
91		"	4.0 V	0.8 V	"	"	"	"	"	"	"	33 V	"	"	"	"	"	"	"	"	"	"	"	"
92		"	4.0 V	4.0 V	"	"	"	"	"	"	"	"	33 V	"	"	"	"	"	"	"	"	"	"	"
93		0.8 V	0.8 V	0.8 V	"	"	"	"	"	"	"	"	"	"	"	OUTB	"	"	"	"	"	"	"	"
94		"	0.8 V	4.0 V	"	"	"	"	"	"	"	"	"	"	"	"	"	"	"	"	"	"	"	"
95		"	4.0 V	0.8 V	"	"	"	"	"	"	"	"	"	"	"	"	"	"	"	"	"	"	"	"
96		"	4.0 V	4.0 V	"	"	"	"	"	"	"	"	"	"	"	"	"	"	"	"	"	"	"	"
97		4.0 V	0.8 V	0.8 V	"	"	"	"	"	"	"	"	"	"	"	"	"	"	"	"	"	"	"	"
98		"	0.8 V	4.0 V	"	"	"	"	"	"	"	"	"	"	"	"	"	"	"	"	"	"	"	"
99		"	4.0 V	0.8 V	"	"	"	"	"	"	"	"	"	"	"	"	"	"	"	"	"	"	"	"
100		"	4.0 V	4.0 V	"	"	"	"	"	"	"	"	"	"	"	"	"	"	"	"	"	"	"	"

TABLE III. Group A inspection for device type 04 – Continued.

Symbol	MIL-STD-883 method	Case X	Terminal conditions 1/														Measured Terminal	Test limits						Unit			
			1	2	3	4	5	6	7	8	9	10	11	12	13	14		Subgroup 1 T _A = 25°C		Subgroup 2 T _A = 125°C		Subgroup 3 T _A = -55°C					
			Test no.	V+	OUTB	NC	IN8B	IN7B	IN6B	IN5B	IN4B	IN3B	IN2B	IN1B	GND	V _{REF}		NC	Min	Max	Min	Max	Min		Max		
I _{D(OFF)} over-voltage		101	15 V													GND		OUTA	-2.0	2.0	-2.0	2.0	-2.0	2.0	μA		
		102	"													"		"	"	"	"	"	"	"	"	"	
		103	"													"		"	"	"	"	"	"	"	"	"	
		104	"													"		"	"	"	"	"	"	"	"	"	
		105	"													"		"	"	"	"	"	"	"	"	"	
		106	"													"		"	"	"	"	"	"	"	"	"	
		107	"													"		"	"	"	"	"	"	"	"	"	
		108	"													"		"	"	"	"	"	"	"	"	"	
		109	"	0 V													-33 V		OUTB	"	"	"	"	"	"	"	"
		110	"	"													-33 V		"	"	"	"	"	"	"	"	"
		111	"	"													-33 V		"	"	"	"	"	"	"	"	"
		112	"	"													-33 V		"	"	"	"	"	"	"	"	"
		113	"	"													-33 V		"	"	"	"	"	"	"	"	"
		114	"	"													-33 V		"	"	"	"	"	"	"	"	"
		115	"	"													-33 V		"	"	"	"	"	"	"	"	"
		116	"	"													-33 V		"	"	"	"	"	"	"	"	"
I+		117	"													"		V+	"	"	"	"	"	"	"	mA	
I-		118	"													"		V-	-1	2.0	-1	2.0	-1	2.0	"	"	
I+SBY		119	"													"		V+	-1.0	2.0	-1.0	2.0	-1.0	2.0	"	"	
I-SBY		120	"													"		V-	-1.0	2.0	-1.0	2.0	-1.0	2.0	"	"	
R _{DS1}		121	"													"		IN1A & OUTA	"	1.5	"	2.0	"	1.5	kΩ		
		122	"													"		IN2A & OUTA	"	"	"	"	"	"	"	"	
		123	"													"		IN3A & OUTA	"	"	"	"	"	"	"	"	
		124	"													"		IN4A & OUTA	"	"	"	"	"	"	"	"	
		125	"													"		IN5A & OUTA	"	"	"	"	"	"	"	"	
		126	"													"		IN6A & OUTA	"	"	"	"	"	"	"	"	
		127	"													"		IN7A & OUTA	"	"	"	"	"	"	"	"	
		128	"													"		IN8A & OUTA	"	"	"	"	"	"	"	"	
		129	"	100 μA													10 V		IN1B & OUTB	"	"	"	"	"	"	"	"
		130	"	"													10 V		IN2B & OUTB	"	"	"	"	"	"	"	"
		131	"	"													10 V		IN3B & OUTB	"	"	"	"	"	"	"	"
		132	"	"													10 V		IN4B & OUTB	"	"	"	"	"	"	"	"
		133	"	"													10 V		IN5B & OUTB	"	"	"	"	"	"	"	"
		134	"	"													10 V		IN6B & OUTB	"	"	"	"	"	"	"	"
		135	"	"													10 V		IN7B & OUTB	"	"	"	"	"	"	"	"
		136	"	"													10 V		IN8B & OUTB	"	"	"	"	"	"	"	"
		137	"	"													"		IN1A & OUTA	"	"	"	"	"	"	"	"
		138	"	"													"		IN2A & OUTA	"	"	"	"	"	"	"	"
		139	"	"													"		IN3A & OUTA	"	"	"	"	"	"	"	"
		140	"	"													"		IN4A & OUTA	"	"	"	"	"	"	"	"
		141	"	"													"		IN5A & OUTA	"	"	"	"	"	"	"	"
		142	"	"													"		IN6A & OUTA	"	"	"	"	"	"	"	"
		143	"	"													"		IN7A & OUTA	"	"	"	"	"	"	"	"
		144	"	"													"		IN8A & OUTA	"	"	"	"	"	"	"	"
		145	"	"													-10 V		IN1B & OUTB	"	"	"	"	"	"	"	"
		146	"	"													-10 V		IN2B & OUTB	"	"	"	"	"	"	"	"
		147	"	"													-10 V		IN3B & OUTB	"	"	"	"	"	"	"	"
		148	"	"													-10 V		IN4B & OUTB	"	"	"	"	"	"	"	"
		149	"	"													-10 V		IN5B & OUTB	"	"	"	"	"	"	"	"
		150	"	"													-10 V		IN6B & OUTB	"	"	"	"	"	"	"	"

See footnotes at end of table.

TABLE III. Group A inspection for device type 04 – Continued.

Symbol	Case X	Terminal conditions 1/														Measured Terminal	Test limits						Unit		
		15	16	17	18	19	20	21	22	23	24	25	26	27	28		Subgroup 1 T _A = 25°C		Subgroup 2 T _A = 125°C		Subgroup 3 T _A = -55°C				
		Test no.	A2	A1	A0	EN	IN1A	IN2A	IN3A	IN4A	IN5A	IN6A	IN7A	IN8A	V-		OUTA	Min	Max	Min	Max	Min		Max	
I _{D(OFF)} over-voltage	101	0.8 V	0.8 V	0.8 V	0.8 V	-33 V									-15 V		OUTA	-2.0	2.0	-2.0	2.0	-2.0	2.0	μA	
	102	"	0.8 V	4.0 V	"		-33 V								"		"	"	"	"	"	"	"	"	"
	103	"	4.0 V	0.8 V	"				-33 V						"		"	"	"	"	"	"	"	"	"
	104	"	4.0 V	4.0 V	"					-33 V					"		"	"	"	"	"	"	"	"	"
	105	4.0 V	0.8 V	0.8 V	"						-33 V				"		"	"	"	"	"	"	"	"	"
	106	"	0.8 V	4.0 V	"							-33 V			"		"	"	"	"	"	"	"	"	"
	107	"	4.0 V	0.8 V	"								-33 V		"		"	"	"	"	"	"	"	"	"
	108	"	4.0 V	4.0 V	"									-33 V	"		"	"	"	"	"	"	"	"	"
	109	0.8 V	0.8 V	0.8 V	"										"		OUTB	"	"	"	"	"	"	"	"
	110	"	0.8 V	4.0 V	"										"		"	"	"	"	"	"	"	"	"
	111	"	4.0 V	0.8 V	"										"		"	"	"	"	"	"	"	"	"
	112	"	4.0 V	4.0 V	"										"		"	"	"	"	"	"	"	"	"
	113	4.0 V	0.8 V	0.8 V	"										"		"	"	"	"	"	"	"	"	"
	114	"	0.8 V	4.0 V	"										"		"	"	"	"	"	"	"	"	"
	115	"	4.0 V	0.8 V	"										"		"	"	"	"	"	"	"	"	"
	116	"	4.0 V	4.0 V	"										"		"	"	"	"	"	"	"	"	"
I+	117	0 V	0 V	0 V	5 V									"		V+								mA	
I-	118	"	"	"	5 V									"		V-	-1		-1					"	
I+SBY	119	"	"	"	0 V									"		V+		2.0		2.0			2.0	"	
I-SBY	120	"	"	"	0 V									"		V-	-1.0		-1.0			-1.0		"	
R _{DS1}	121	0.8 V	0.8 V	0.8 V	4.0 V	10 V									100 μA	IN1A & OUTA		1.5		2.0		1.5	kΩ		
	122	"	0.8 V	4.0 V	"		10 V								"	IN2A & OUTA		"		"		"	"		
	123	"	4.0 V	0.8 V	"			10 V							"	IN3A & OUTA		"		"		"	"		
	124	"	4.0 V	4.0 V	"				10 V						"	IN4A & OUTA		"		"		"	"		
	125	4.0 V	0.8 V	0.8 V	"					10 V					"	IN5A & OUTA		"		"		"	"		
	126	"	0.8 V	4.0 V	"						10 V				"	IN6A & OUTA		"		"		"	"		
	127	"	4.0 V	0.8 V	"							10 V			"	IN7A & OUTA		"		"		"	"		
	128	"	4.0 V	4.0 V	"								10 V		"	IN8A & OUTA		"		"		"	"		
	129	0.8 V	0.8 V	0.8 V	"										"	IN1B & OUTB		"		"		"	"		
	130	"	0.8 V	4.0 V	"										"	IN2B & OUTB		"		"		"	"		
	131	"	4.0 V	0.8 V	"										"	IN3B & OUTB		"		"		"	"		
	132	"	4.0 V	4.0 V	"										"	IN4B & OUTB		"		"		"	"		
	133	4.0 V	0.8 V	0.8 V	"										"	IN5B & OUTB		"		"		"	"		
	134	"	0.8 V	4.0 V	"										"	IN6B & OUTB		"		"		"	"		
	135	"	4.0 V	0.8 V	"										"	IN7B & OUTB		"		"		"	"		
	136	"	4.0 V	4.0 V	"										"	IN8B & OUTB		"		"		"	"		
	137	0.8 V	0.8 V	0.8 V	"	-10 V									"	-100 μA	IN1A & OUTA		"		"		"	"	
	138	"	0.8 V	4.0 V	"		-10 V								"	"	IN2A & OUTA		"		"		"	"	
	139	"	4.0 V	0.8 V	"			-10 V							"	"	IN3A & OUTA		"		"		"	"	
	140	"	4.0 V	4.0 V	"				-10 V						"	"	IN4A & OUTA		"		"		"	"	
	141	4.0 V	0.8 V	0.8 V	"						-10 V				"	"	IN5A & OUTA		"		"		"	"	
	142	"	0.8 V	4.0 V	"							-10 V			"	"	IN6A & OUTA		"		"		"	"	
	143	"	4.0 V	0.8 V	"								-10 V		"	"	IN7A & OUTA		"		"		"	"	
	144	"	4.0 V	4.0 V	"									-10 V	"	"	IN8A & OUTA		"		"		"	"	
	145	0.8 V	0.8 V	0.8 V	"										"	"	IN1B & OUTB		"		"		"	"	
	146	"	0.8 V	4.0 V	"										"	"	IN2B & OUTB		"		"		"	"	
	147	"	4.0 V	0.8 V	"										"	"	IN3B & OUTB		"		"		"	"	
	148	"	4.0 V	4.0 V	"										"	"	IN4B & OUTB		"		"		"	"	
	149	4.0 V	0.8 V	0.8 V	"										"	"	IN5B & OUTB		"		"		"	"	
	150	4.0 V	0.8 V	4.0 V	"										"	"	IN6B & OUTB		"		"		"	"	

TABLE III. Group A inspection for device type 04 – Continued.

Symbol	MIL-STD-883 method	Case X	Terminal conditions 1/														Measured Terminal	Test limits						Unit				
			1	2	3	4	5	6	7	8	9	10	11	12	13	14		Subgroup 1 T _A = 25°C		Subgroup 2 T _A = 125°C		Subgroup 3 T _A = -55°C						
			Test no.	V+	OUTB	NC	IN8B	IN7B	IN6B	IN5B	IN4B	IN3B	IN2B	IN1B	GND	V _{REF}		NC	Min	Max	Min	Max	Min		Max			
R _{DS1}		151	15 V	-100 μA												GND			IN7B		1.5		2.0		1.5	kΩ		
		152	15 V	-100 μA				-10 V									GND			IN8B		1.5		2.0		1.5	kΩ	
R _{DS2}	153 thru 168 – Same terminal conditions as for tests 121 thru 136, except V _± = ±10 V, V _S = +7.5 V, and limits as shown.																			2.4		2.4		2.4		2.4		"
R _{DS2}	169 thru 184 – Same terminal conditions as for tests 137 thru 152, except V _± = ±10 V, V _S = -7.5 V, and limits as shown.																			2.4		2.4		2.4		2.4		"
																			Subgroup 4 T _A = 25°C									
																			Min	Max								
C _A	3012	185	GND													GND			A2		10					pF		
	"	186	"													"			A1		10					"		
C _{OS}	"	187	"													"			A0		10					"		
	"	188	"													"			OUTA		50					"		
C _{IS}	"	189	"	5/												"			OUTB		50					"		
	"	190	"													"			IN1A		10					"		
	"	191	"													"			IN2A		"					"		
	"	192	"													"			IN3A		"					"		
	"	193	"													"			IN4A		"					"		
	"	194	"													"			IN5A		"					"		
	"	195	"													"			IN6A		"					"		
	"	196	"													"			IN7A		"					"		
	"	197	"													"			IN8A		"					"		
	"	198	"											4/		"			IN1B		"					"		
	"	199	"											4/		"			IN2B		"					"		
	"	200	"											4/		"			IN3B		"					"		
	"	201	"											4/		"			IN4B		"					"		
	"	202	"											4/		"			IN5B		"					"		
	"	203	"											4/		"			IN6B		"					"		
	"	204	"											4/		"			IN7B		"					"		
	"	205	"											4/		"			IN8B		"					"		
C _{EN}	"	206	"												"			EN		"						"		
																			Subgroup 9 T _A = 25°C		Subgroup 10 T _A = 125°C		Subgroup 11 T _A = -55°C					
																			Min	Max	Min	Max	Min	Max				
t _{ON(A)} and t _{OFF(A)}	3003 fig. 8	207	15 V			GND	GND	GND	GND	GND	GND	GND	GND	GND	GND	GND	GND		ADDRESS IN TO OUTA		1,000		1,500		1,000	ns		
	"	208	"			"	"	"	"	"	"	"	"	"	"	"	"		"		"		"		"	"		
	"	209	"			"	"	"	"	"	"	"	"	"	"	"	"		"		"		"		"	"		
	"	210	"			"	"	"	"	"	"	"	"	"	"	"	"		"		"		"		"	"		
	"	211	"			"	"	"	"	"	"	"	"	"	"	"	"		"		"		"		"	"		
	"	212	"			"	"	"	"	"	"	"	"	"	"	"	"		"		"		"		"	"		
	"	213	"			"	"	"	"	"	"	"	"	"	"	"	"		"		"		"		"	"		
	"	214	"			"	"	"	"	"	"	"	"	"	"	"	"		"		"		"		"	"		
	"	215	"	OUT			10 V	"	"	"	"	"	"	"	"	"	"		ADDRESS IN TO OUTB		"		"		"	"		
	"	216	"	"			-10 V	"	"	"	"	"	"	"	"	"	"		"		"		"		"	"		
	"	217	"	"			10 V	"	"	"	"	"	"	"	"	"	"		"		"		"		"	"		
	"	218	"	"			-10 V	"	"	"	"	"	"	"	"	"	"		"		"		"		"	"		
"	219	"	"			GND	"	"	"	"	"	"	"	"	"	"		"		"		"		"	"			
"	220	"	"			"	"	"	"	"	"	"	"	"	"	"		"		"		"		"	"			
"	221	"	"			"	"	"	"	"	"	"	"	"	"	"		"		"		"		"	"			
"	222	"	"			"	"	"	"	"	"	"	"	"	"	"		"		"		"		"	"			

See footnotes at end of table.

TABLE III. Group A inspection for device type 04 – Continued.

Symbol	MIL-STD-883 method	Case X	Terminal conditions 1/														Measured Terminal	Test limits						Unit			
			15	16	17	18	19	20	21	22	23	24	25	26	27	28		Subgroup 1 T _A = 25°C		Subgroup 2 T _A = 125°C		Subgroup 3 T _A = -55°C					
			Test no.	A2	A1	A0	EN	IN1A	IN2A	IN3A	IN4A	IN5A	IN6A	IN7A	IN8A	V-		OUTA	Min	Max	Min	Max	Min		Max		
R _{DS1}		151																IN7B		1.5		2.0		1.5	kΩ		
		152																	IN8B		1.5		2.0		1.5	kΩ	
R _{DS2}	153 thru 168 – Same terminal conditions as for tests 121 thru 136, except V _± = ±10 V, V _S = +7.5 V, and limits as shown.																2.4		2.4		2.4						"
R _{DS2}	169 thru 184 – Same terminal conditions as for tests 137 thru 152, except V _± = ±10 V, V _S = -7.5 V, and limits as shown.																2.4		2.4		2.4						"
C _A		185	4/														GND	A2	Min	Max					pF		
		186		4/														"	A1							"	
C _{OS}		187			4/													"	A0							"	
		188	0 V	0 V	0 V	0 V												"	5/	OUTA							"
C _{IS}		189	"	"	"	"												"	5/	OUTB							"
		190	"	"	"	"	4/											"	"	IN1A							"
		191	"	"	"	"	"	4/										"	"	IN2A							"
		192	"	"	"	"	"	"	4/									"	"	IN3A							"
		193	"	"	"	"	"	"	"	4/								"	"	IN4A							"
		194	"	"	"	"	"	"	"	"	4/							"	"	IN5A							"
		195	"	"	"	"	"	"	"	"	"	4/						"	"	IN6A							"
		196	"	"	"	"	"	"	"	"	"	"	4/					"	"	IN7A							"
		197	"	"	"	"	"	"	"	"	"	"	"	4/				"	"	IN8A							"
		198	"	"	"	"	"	"	"	"	"	"	"	"	4/			"	"	IN1B							"
		199	"	"	"	"	"	"	"	"	"	"	"	"	"	4/		"	"	IN2B							"
		200	"	"	"	"	"	"	"	"	"	"	"	"	"	"	4/	"	"	IN3B							"
		201	"	"	"	"	"	"	"	"	"	"	"	"	"	"	"	4/	"	IN4B							"
		202	"	"	"	"	"	"	"	"	"	"	"	"	"	"	"	"	"	IN5B							"
		203	"	"	"	"	"	"	"	"	"	"	"	"	"	"	"	"	"	IN6B							"
	204	"	"	"	"	"	"	"	"	"	"	"	"	"	"	"	"	"	IN7B							"	
	205	"	"	"	"	"	"	"	"	"	"	"	"	"	"	"	"	"	IN8B							"	
C _{EN}		206				4/												"	EN							"	
t _{ON(A)} and t _{OFF(A)}		207				5/	GND	GND	GND	GND	GND	GND	GND	10 V	-15 V			"	ADDRESS IN TO OUTA	Min	Max	1,000		1,500		1,000	ns
		208				"	"	"	"	"	"	"	"	"	-10 V	"			"	"							"
	209				"	"	"	"	"	"	"	"	"	10 V	"			"	"							"	
	210				"	"	"	"	"	"	"	"	"	-10 V	"			"	"							"	
	211				"	"	10 V	"	"	"	"	"	"	GND	"			"	"							"	
	212				"	"	-10 V	"	"	"	"	"	"	"	"			"	"							"	
	213				"	"	10 V	"	"	"	"	"	"	"	"			"	"							"	
	214				"	"	-10 V	"	"	"	"	"	"	"	"			"	"							"	
	215				"	"	GND	"	"	"	"	"	"	"	"			"	ADDRESS IN TO OUTB							"	
	216				"	"	"	"	"	"	"	"	"	"	"			"	"							"	
	217				"	"	"	"	"	"	"	"	"	"	"			"	"							"	
	218				"	"	"	"	"	"	"	"	"	"	"			"	"							"	
	219				"	"	"	"	"	"	"	"	"	"	"			"	"							"	
	220				"	"	"	"	"	"	"	"	"	"	"			"	"							"	
	221				"	"	"	"	"	"	"	"	"	"	"			"	"							"	
	222				"	"	"	"	"	"	"	"	"	"	"			"	"							"	

See footnotes at end of table.

TABLE III. Group A inspection for device type 04 – Continued.

Symbol	MIL-STD-883 method	Case X	Terminal conditions 1/														Measured Terminal	Test limits						Unit	
			1	2	3	4	5	6	7	8	9	10	11	12	13	14		Subgroup 9 T _A = 25°C		Subgroup 10 T _A = 125°C		Subgroup 11 T _A = -55°C			
			Test no.	V+	OUTB	NC	IN8B	IN7B	IN6B	IN5B	IN4B	IN3B	IN2B	IN1B	GND	V _{REF}		NC	Min	Max	Min	Max	Min		Max
t _{ON(EN)} and t _{OFF(EN)}	3003 fig. 9	223	15 V			GND	GND	GND	GND	GND	GND	GND	GND	GND	GND	GND	ENABLE		1,000		1,500		1,000	ns	
		224	"			"	"	"	"	"	"	"	"	"	"	"	"	TO OUTA	"	"	"	"	"	"	
		225	"			"	"	"	"	"	"	"	"	"	"	"	"	"	"	"	"	"	"	"	
		226	"			"	"	"	"	"	"	"	"	"	"	"	"	"	"	"	"	"	"	"	
		227	"	OUT			10 V	10 V	10 V	10 V	10 V	10 V	10 V	10 V	10 V	10 V	"	ENABLE	"	"	"	"	"	"	
		228	"	"			-10 V	-10 V	-10 V	-10 V	-10 V	-10 V	-10 V	-10 V	-10 V	-10 V	"	TO OUTB	"	"	"	"	"	"	
		229	"	"			10 V	10 V	10 V	10 V	10 V	10 V	10 V	10 V	10 V	10 V	"	"	"	"	"	"	"	"	
230	"	"			-10 V	-10 V	-10 V	-10 V	-10 V	-10 V	-10 V	-10 V	-10 V	-10 V	"	"	"	"	"	"	"	"	"		
																		Subgroup 12 T _A = 25°C							
																		Min	Max						
V _{ISO}	fig. 15	231	15 V			IN	IN	IN	IN	IN	IN	IN	IN	IN	GND		OUTA	50					dB		
	fig. 15	232	"	OUT		"	"	"	"	"	"	"	"	"	"	"	OUTB	"					"		
V _{CT}	fig. 16	233	"			"	"	"	"	"	"	"	"	"	6/	"	OUTA	"					"		
	fig. 16	234	"	OUT		"	"	"	"	"	"	"	"	"	6/	"	OUTB	"					"		
V _{CTE}	fig. 17	235	"												GND	"	OUTA		10				mV		
	fig. 17	236	"	OUT											GND	"	OUTB		10				mV		
																		Subgroup 13 T _A = 25°C							
																		Min	Max						
t _D	fig. 14	237	15 V			GND	GND	GND	GND	GND	GND	GND	GND	GND	GND	GND	OUTA	5					ns		
	"	238	"			"	"	"	"	"	"	"	"	"	"	"	"	"	"	"	"	"	"		
	"	239	"			"	"	"	"	"	"	"	"	"	"	"	"	"	"	"	"	"	"		
	"	240	"			"	"	"	"	"	"	"	"	"	"	"	"	"	"	"	"	"	"		
	"	241	"	OUT			10 V	10 V	10 V	10 V	10 V	10 V	10 V	10 V	10 V	10 V	"	OUTB	"	"	"	"	"		
	"	242	"	"			-10 V	-10 V	-10 V	-10 V	-10 V	-10 V	-10 V	-10 V	-10 V	-10 V	"	"	"	"	"	"	"		
	"	243	"	"			10 V	10 V	10 V	10 V	10 V	10 V	10 V	10 V	10 V	10 V	"	"	"	"	"	"	"		
"	244	"	"			-10 V	-10 V	-10 V	-10 V	-10 V	-10 V	-10 V	-10 V	-10 V	-10 V	"	"	"	"	"	"	"			

See footnotes at end of table.

TABLE III. Group A inspection for device type 04 – Continued.

Symbol	MIL-STD-883 method	Case X	Terminal conditions 1/														Measured Terminal	Test limits						Unit		
			15	16	17	18	19	20	21	22	23	24	25	26	27	28		Subgroup 9 T _A = 25°C		Subgroup 10 T _A = 125°C		Subgroup 11 T _A = -55°C				
			Test no.	A2	A1	A0	EN	IN1A	IN2A	IN3A	IN4A	IN5A	IN6A	IN7A	IN8A	V-		OUTA	Min	Max	Min	Max	Min		Max	
t _{ON(EN)} and t _{OFF(EN)}		223	GND	GND	GND		10 V	10 V	10 V	10 V	10 V	10 V	10 V	10 V	10 V	10 V	-15 V	OUT	ENABLE TO OUTA		1,000		1,500		1,000	ns
		224	"	"	"		-10 V	-10 V	-10 V	-10 V	-10 V	-10 V	-10 V	-10 V	"	"	"	"	"	"	"	"	"	"	"	
		225	"	"	"		10 V	10 V	10 V	10 V	10 V	10 V	10 V	10 V	"	"	"	"	"	"	"	"	"	"	"	
		226	"	"	"		-10 V	-10 V	-10 V	-10 V	-10 V	-10 V	-10 V	-10 V	"	"	"	"	"	"	"	"	"	"	"	
		227	"	"	"		GND	GND	GND	GND	GND	GND	GND	GND	"	"	"	"	ENABLE TO OUTB	"	"	"	"	"	"	"
		228	"	"	"		"	"	"	"	"	"	"	"	"	"	"	"	"	"	"	"	"	"	"	
		229	"	"	"		"	"	"	"	"	"	"	"	"	"	"	"	"	"	"	"	"	"	"	
	230	"	"	"		"	"	"	"	"	"	"	"	"	"	"	"	"	"	"	"	"	"	"		
																	Subgroup 12 T _A = 25°C									
																	Min	Max								
V _{ISO}		231	GND	GND	GND	0 V	IN	IN	IN	IN	IN	IN	IN	IN	IN	IN	-15 V	OUT	OUTA	50					dB	
		232	"	"	"	0 V	"	"	"	"	"	"	"	"	"	"	"	"	OUTB	"	"	"	"	"	"	
V _{CT}		233	"	"	"	5 V	6/	"	"	"	"	"	"	"	"	"	"	OUT	OUTA	"	"	"	"	"	"	
		234	"	"	"	"	6/	"	"	"	"	"	"	"	"	"	"	"	OUTB	"	"	"	"	"	"	
V _{CTE}		235	IN	IN	IN	"	GND	"	"	"	"	"	"	"	"	"	"	OUT	OUTA	10					mV	
		236	IN	IN	IN	"	GND	"	"	"	"	"	"	"	"	"	"	"	OUTB	10					mV	
																	Subgroup 13 T _A = 25°C									
																	Min	Max								
t _D		237				5 V	10 V	10 V	10 V	10 V	10 V	10 V	10 V	10 V	10 V	10 V	-15 V	OUT	OUTA	5					ns	
		238				"	-10 V	-10 V	-10 V	-10 V	-10 V	-10 V	-10 V	-10 V	-10 V	-10 V	"	"	"	"	"	"	"	"	"	
		239				"	10 V	10 V	10 V	10 V	10 V	10 V	10 V	10 V	10 V	10 V	"	"	"	"	"	"	"	"	"	
		240				"	-10 V	-10 V	-10 V	-10 V	-10 V	-10 V	-10 V	-10 V	-10 V	-10 V	"	"	"	"	"	"	"	"	"	
		241				"	GND	GND	GND	GND	GND	GND	GND	GND	GND	GND	"	"	"	OUTB	"	"	"	"	"	"
		242				"	"	"	"	"	"	"	"	"	"	"	"	"	"	"	"	"	"	"	"	
		243				"	"	"	"	"	"	"	"	"	"	"	"	"	"	"	"	"	"	"	"	
	244				"	"	"	"	"	"	"	"	"	"	"	"	"	"	"	"	"	"	"	"		

See footnotes at end of table.

TABLE III. Group A inspection for device type 05.

Symbol	MIL-STD-883 test method	Case E	Terminal conditions 1/																Measured Terminal	Test limits						Unit			
			1	2	3	4	5	6	7	8	9	10	11	12	13	14	15	16		Subgroup 1 T _A = 25°C		Subgroup 2 T _A = 125°C		Subgroup 3 T _A = -55°C					
			Test no.	A0	EN	V-	IN1	IN2	IN3	IN4	OUT	IN8	IN7	IN6	IN5	V+	GND	A2		A1	Min	Max	Min	Max	Min		Max		
V _{IC(POS)}		1													GND		1 mA	A2		1.5					V				
			2															1 mA	A1										
			3	1 mA																A0									
			4		1mA															EN									
V _{IC(NEG)}		5			GND											GND	-1 mA	A2	-1.5										
			6																A1										
			7	-1 mA																A0									
			8		-1 mA															EN									
I _{IH} 2/	3010	9	GND	5 V	-15 V									15 V		4.0 V	GND	A2	-0.1	1.0	-0.1	1.0	-0.1	1.0	μA				
			10	GND													GND	4.0 V	A1										
			11	4.0 V															GND	A0									
			12	GND	4.0 V															EN									
I _{IL} 2/	3009	13	5 V	5 V												0.8 V	5 V	A2	-1.0	0.1	-1.0	0.1	-1.0	0.1					
			14	5 V	5 V												5 V	0.8 V	A1										
			15	0.8 V	5 V												5 V	5 V	A0										
			16	5 V	0.8 V												5 V	5 V	EN										
I _{S(OFF)} 3/		17	0.8 V			10 V	-10 V	-10 V	-10 V		-10 V	-10 V	-10 V	-10 V			0.8 V	0.8 V	IN1	-1	1	-50	50	-50	50	nA			
			18	4.0 V			-10 V	10 V	-10 V	-10 V									0.8 V	IN2									
			19	0.8 V				-10 V	10 V	-10 V										4.0 V	IN3								
			20	4.0 V					-10 V	10 V										4.0 V	IN4								
			21	0.8 V												10 V			4.0 V	0.8 V	IN5								
			22	4.0 V												10 V	-10 V			0.8 V	IN6								
			23	0.8 V									10 V	-10 V	-10 V					4.0 V	IN7								
			24	4.0 V									10 V	-10 V	-10 V	-10 V				4.0 V	IN8								
			25	0.8 V				10 V	10 V	10 V	10 V			10 V	10 V	10 V			0.8 V	0.8 V	IN1								
			26	4.0 V				10 V	-10 V	10 V	10 V									0.8 V	IN2								
			27	0.8 V					10 V	-10 V	10 V										4.0 V	IN3							
			28	4.0 V						10 V	-10 V										4.0 V	IN4							
			29	0.8 V												-10 V			4.0 V	0.8 V	IN5								
			30	4.0 V												-10 V	10 V			0.8 V	IN6								
			31	0.8 V												-10 V	10 V	10 V		4.0 V	IN7								
			32	4.0 V												10 V	10 V	10 V		4.0 V	IN8								
I _{D(OFF)}		33	0.8 V			-10 V	-10 V	-10 V	-10 V	10 V	-10 V	-10 V	-10 V	-10 V			0.8 V	0.8 V	OUT	-10	10	-250	250	-250	250				
I _{D(OFF)}		34	0.8 V			10 V	10 V	10 V	10 V	-10 V	10 V	10 V	10 V	10 V					OUT										
I _{D(ON)}		35	0.8 V	4.0 V		10 V	-10 V	-10 V	-10 V	10 V	-10 V	-10 V	-10 V	-10 V					IN1 & OUT										
			36	4.0 V			-10 V	10 V	-10 V	-10 V										IN2 & OUT									
			37	0.8 V				-10 V	10 V	-10 V										4.0 V	IN3 & OUT								
			38	4.0 V					-10 V	10 V										4.0 V	IN4 & OUT								
			39	0.8 V							-10 V					10 V			4.0 V	0.8 V	IN5 & OUT								
			40	4.0 V											10 V	-10 V				0.8 V	IN6 & OUT								
			41	0.8 V											10 V	-10 V	-10 V			4.0 V	IN7 & OUT								
			42	4.0 V											-10 V	-10 V	-10 V			4.0 V	IN8 & OUT								

See footnotes at end of table.

TABLE III. Group A inspection for device type 05 - Continued.

Symbol	MIL-STD-883 test method	Case E	Terminal conditions ^{1/}																Measured Terminal	Test limits						Unit
			1	2	3	4	5	6	7	8	9	10	11	12	13	14	15	16		Subgroup 1 T _A = 25°C		Subgroup 2 T _A = 125°C		Subgroup 3 T _A = -55°C		
			Test no.	A0	EN	V-	IN1	IN2	IN3	IN4	OUT	IN8	IN7	IN6	IN5	V+	GND	A2		A1	Min	Max	Min	Max	Min	
I _{D(ON)}		43	0.8 V	4.0 V	-15 V	-10 V	10 V	10 V	10 V	-10 V	10 V	10 V	10 V	10 V	15 V	GND	0.8 V	0.8 V	IN1 & OUT	-10	10	-250	250	-250	250	nA
		44	4.0 V	"	"	10 V	-10 V	10 V	10 V	"	"	"	"	"	"	"	"	0.8 V	IN2 & OUT	"	"	"	"	"	"	"
		45	0.8 V	"	"	"	10 V	-10 V	10 V	10 V	"	"	"	"	"	"	"	4.0 V	IN3 & OUT	"	"	"	"	"	"	"
		46	4.0 V	"	"	"	"	10 V	-10 V	"	"	"	"	"	"	"	"	4.0 V	IN4 & OUT	"	"	"	"	"	"	"
		47	0.8 V	"	"	"	"	"	10 V	"	"	"	"	"	-10 V	"	"	0.8 V	IN5 & OUT	"	"	"	"	"	"	"
		48	4.0 V	"	"	"	"	"	"	"	"	"	"	-10 V	10 V	"	"	0.8 V	IN6 & OUT	"	"	"	"	"	"	"
		49	0.8 V	"	"	"	"	"	"	"	"	"	-10 V	10 V	10 V	"	"	4.0 V	IN7 & OUT	"	"	"	"	"	"	"
		50	4.0 V	"	"	"	"	"	"	"	-10 V	10 V	10 V	10 V	"	"	"	4.0 V	IN8 & OUT	"	"	"	"	"	"	"
I+		51	0 V	5.0 V	"	"	"	"	"	"	"	"	"	"	"	0 V	0 V	V+	-1	2.0	-1	2.0	-1	2.0	mA	
I-		52	"	5.0 V	"	"	"	"	"	"	"	"	"	"	"	"	"	V-	"	"	"	"	"	"	"	
I+SBY		53	"	0 V	"	"	"	"	"	"	"	"	"	"	"	"	"	V+	-1.0	2.0	-1.0	2.0	-1.0	2.0	"	
I-SBY		54	"	0 V	"	"	"	"	"	"	"	"	"	"	"	"	"	V-	"	"	"	"	"	"	"	
I _{D(OFF)} over-voltage		55	0.8 V	0.8 V	"	33 V	"	"	"	0 V	"	"	"	"	"	"	GND	0.8 V	OUT	-2.0	2.0	-2.0	2.0	-2.0	2.0	μA
		56	4.0 V	"	"	"	33 V	"	"	"	"	"	"	"	"	"	"	0.8 V	"	"	"	"	"	"	"	
		57	0.8 V	"	"	"	"	33 V	"	"	"	"	"	"	"	"	"	4.0 V	"	"	"	"	"	"	"	
		58	4.0 V	"	"	"	"	"	33 V	"	"	"	"	"	"	"	"	4.0 V	"	"	"	"	"	"	"	
		59	0.8 V	"	"	"	"	"	"	"	"	"	33 V	"	"	"	15 V	0.8 V	"	"	"	"	"	"	"	
		60	4.0 V	"	"	"	"	"	"	"	"	"	"	33 V	"	"	"	0.8 V	"	"	"	"	"	"	"	
		61	0.8 V	"	"	"	"	"	"	"	"	"	33 V	"	"	"	"	4.0 V	"	"	"	"	"	"	"	
		62	4.0 V	"	"	"	"	"	"	"	33 V	"	"	"	"	"	"	4.0 V	"	"	"	"	"	"	"	
I _{D(OFF)} over-voltage		63	0.8 V	"	"	-33 V	"	"	"	"	"	"	"	"	"	"	GND	0.8 V	"	"	"	"	"	"	"	
		64	4.0 V	"	"	"	-33 V	"	"	"	"	"	"	"	"	"	"	0.8 V	"	"	"	"	"	"	"	
		65	0.8 V	"	"	"	"	-33 V	"	"	"	"	"	"	"	"	"	4.0 V	"	"	"	"	"	"	"	
		66	4.0 V	"	"	"	"	"	-33 V	"	"	"	"	"	"	"	"	4.0 V	"	"	"	"	"	"	"	
		67	0.8 V	"	"	"	"	"	"	"	"	"	"	-33 V	"	"	15 V	0.8 V	"	"	"	"	"	"	"	
		68	4.0 V	"	"	"	"	"	"	"	"	"	-33 V	"	"	"	"	0.8 V	"	"	"	"	"	"	"	
		69	0.8 V	"	"	"	"	"	"	"	"	"	-33 V	"	"	"	"	4.0 V	"	"	"	"	"	"	"	
		70	4.0 V	"	"	"	"	"	"	"	-33 V	"	"	"	"	"	"	4.0 V	"	"	"	"	"	"	"	
R _{DS1}		71	0.8 V	4.0 V	"	10 V	"	"	"	100 μA	"	"	"	"	"	"	0.8 V	0.8 V	IN1 & OUT	1.5		1.8		1.5	kΩ	
		72	4.0 V	"	"	"	10 V	"	"	"	"	"	"	"	"	"	"	0.8 V	IN2 & OUT	"	"	"	"	"	"	
		73	0.8 V	"	"	"	"	10 V	"	"	"	"	"	"	"	"	"	4.0 V	IN3 & OUT	"	"	"	"	"	"	
		74	4.0 V	"	"	"	"	"	10 V	"	"	"	"	"	"	"	"	4.0 V	IN4 & OUT	"	"	"	"	"	"	
		75	0.8 V	"	"	"	"	"	"	"	"	"	10 V	"	"	"	4.0 V	0.8 V	IN5 & OUT	"	"	"	"	"	"	
		76	4.0 V	"	"	"	"	"	"	"	"	"	"	10 V	"	"	"	0.8 V	IN6 & OUT	"	"	"	"	"	"	
		77	0.8 V	"	"	"	"	"	"	"	"	10 V	"	"	"	"	"	4.0 V	IN7 & OUT	"	"	"	"	"	"	
		78	4.0 V	"	"	"	"	"	"	10 V	"	"	"	"	"	"	"	4.0 V	IN8 & OUT	"	"	"	"	"	"	
		79	0.8 V	"	"	-10 V	"	"	"	"	-100 μA	"	"	"	"	"	"	0.8 V	0.8 V	IN1 & OUT	"	"	"	"	"	"
		80	4.0 V	"	"	"	-10 V	"	"	"	"	"	"	"	"	"	"	0.8 V	IN2 & OUT	"	"	"	"	"	"	
		81	0.8 V	"	"	"	"	-10 V	"	"	"	"	"	"	"	"	"	4.0 V	IN3 & OUT	"	"	"	"	"	"	
		82	4.0 V	"	"	"	"	"	-10 V	"	"	"	"	"	"	"	"	4.0 V	IN4 & OUT	"	"	"	"	"	"	
		83	0.8 V	"	"	"	"	"	"	"	"	"	"	-10 V	"	"	4.0 V	0.8 V	IN5 & OUT	"	"	"	"	"	"	
		84	4.0 V	"	"	"	"	"	"	"	"	"	-10 V	"	"	"	"	0.8 V	IN6 & OUT	"	"	"	"	"	"	
		85	0.8 V	"	"	"	"	"	"	"	"	"	-10 V	"	"	"	"	4.0 V	IN7 & OUT	"	"	"	"	"	"	
		86	4.0 V	"	"	"	"	"	"	"	"	-10 V	"	"	"	"	"	4.0 V	IN8 & OUT	"	"	"	"	"	"	
R _{DS2}		87 thru 102 – Same terminal conditions as for tests 71 thru 86, except V _± = ±10 V, V _S = ±7.5, and limits as shown.																		2.2		2.2		2.2		"

See footnotes at end of table.

TABLE III. Group A inspection for device type 05 - Continued.

Symbol	MIL-STD-883 test method	Case E	Terminal conditions 1/																Measured Terminal	Test limits				Unit					
			1	2	3	4	5	6	7	8	9	10	11	12	13	14	15	16		Subgroup 1 T _A = 25°C									
			Test no.	A0	EN	V-	IN1	IN2	IN3	IN4	OUT	IN8	IN7	IN6	IN5	V+	GND	A2		A1	Min	Max							
C _A	3012	103			GND										GND	GND	4/		A2		10				pF				
		104																4/		A1		10				"			
		105	4/																	A0		10				"			
		106	0 V								5/							0 V	0 V	OUT		45				"			
C _{IS}	107	107		0 V		4/													IN1		10				"				
		108					4/												IN2						"				
		109						4/											IN3						"				
		110							4/										IN4						"				
		111									4/								IN5						"				
		112											4/						IN6						"				
		113												4/					IN7						"				
		114													4/				IN8						"				
C _{EN}	115		4/															EN											
																				Subgroup 9 T _A = 25°C		Subgroup 10 T _A = 125°C		Subgroup 11 T _A = -55°C					
t _{ON(A)} and t _{OFF(A)}	3003 fig. 10	116		5 V	-15 V	GND	GND	GND	GND	OUT	10 V	GND	GND	GND	15 V	GND			OUT		Min	1,000	Max					ns	
		117										-10 V																	"
		118										10 V																	"
		119										-10 V																	"
		120					10 V																						"
		121					-10 V																						"
		122					10 V																						"
t _{ON(EN)} and t _{OFF(EN)}	3003 fig. 11	123				-10 V																					"		
		124	GND			10 V	10 V	10 V	10 V		10 V	10 V	10 V	10 V				GND	GND									"	
		125					-10 V	-10 V	-10 V	-10 V		-10 V	-10 V	-10 V	-10 V														"
		126					10 V	10 V	10 V	10 V		10 V	10 V	10 V	10 V														"
		127					-10 V	-10 V	-10 V	-10 V		-10 V	-10 V	-10 V	-10 V												"		
																				Subgroup 12 T _A = 25°C									
V _{ISO}	fig. 15	128	GND	0 V	-15 V	IN	IN	IN	IN	OUT	IN	IN	IN	IN	15 V	GND	GND	GND	OUT		Min	50	Max					dB	
V _{CT}	fig. 16	129	GND	5 V	-15 V	6/	IN	IN	IN	OUT	IN	IN	IN	IN	15 V	GND	GND	GND	OUT		50							dB	
V _{CTE}	fig. 17	130	IN	5 V	-15 V	GND									15 V	GND	IN	IN	OUT		10							mV	
																				Subgroup 13 T _A = 25°C									
t _b	fig. 14	131		5 V	-15 V	10 V	10 V	10 V	10 V	OUT	10 V	10 V	10 V	10 V	15 V	GND			OUT		Min	5	Max					ns	
		132					-10 V	-10 V	-10 V	-10 V		-10 V	-10 V	-10 V	-10 V													"	
		133					10 V	10 V	10 V	10 V		10 V	10 V	10 V	10 V													"	
		134					-10 V	-10 V	-10 V	-10 V		-10 V	-10 V	-10 V	-10 V													"	

See footnotes at end of table.

TABLE III. Group A inspection for device type 06.

Symbol	MIL-STD-883 test method	Case E	Terminal conditions 1/																Measured Terminal	Test limits						Unit				
			1	2	3	4	5	6	7	8	9	10	11	12	13	14	15	16		Subgroup 1 T _A = 25°C		Subgroup 2 T _A = 125°C		Subgroup 3 T _A = -55°C						
			Test no.	A0	EN	V-	IN1A	IN2A	IN3A	IN4A	OUTA	OUTB	IN4B	IN3B	IN2B	IN1B	V+	GND		A1	Min	Max	Min	Max	Min		Max			
V _{IC(POS)}		1																GND		1 mA	A1		1.5					V		
		2	1 mA															GND			A0		1.5						"	
		3		1 mA														GND		-1 mA	EN		1.5						"	
V _{IC(NEG)}		4			GND														GND		A1		-1.5					"		
		5	-1 mA		GND																A0		-1.5					"		
		6		-1 mA	GND																EN		-1.5					"		
I _{IH} 2/		7	GND	5 V	-15 V													15 V		4.0 V	A1	-0.1	1.0	-0.1	1.0	-0.1	1.0	μA		
		8	4.0 V	5 V																GND	A0	-0.1	1.0	-0.1	1.0	-0.1	1.0	"		
	3010	9	GND	4.0 V																GND	EN	-0.1	1.0	-0.1	1.0	-0.1	1.0	"		
I _{IL} 2/	"	10	5.0 V	5 V																0.8 V	A1	-1.0	0.1	-1.0	0.1	-1.0	0.1	"		
	"	11	0.8 V	5 V																5.0 V	A0	-1.0	0.1	-1.0	0.1	-1.0	0.1	"		
	"	12	5.0 V	0.8 V																5.0 V	EN	-1.0	0.1	-1.0	0.1	-1.0	0.1	"		
	"	13	0.8 V			10 V	-10 V	-10 V	-10 V	-10 V	-10 V	-10 V	-10 V	-10 V	-10 V	-10 V	-10 V	-10 V	-10 V	0.8 V	IN1A	-1	1	-50	50	-50	50	nA		
I _{S(OFF)} 3/	"	14	4.0 V			-10 V	10 V	-10 V	-10 V	-10 V	-10 V	-10 V	-10 V	-10 V	-10 V	-10 V	-10 V	-10 V	0.8 V	IN2A								"		
	"	15	0.8 V				-10 V	10 V	-10 V	-10 V	-10 V	-10 V	-10 V	-10 V	-10 V	-10 V	-10 V	-10 V	4.0 V	IN3A									"	
	"	16	4.0 V					-10 V	10 V	-10 V	-10 V	-10 V	-10 V	-10 V	-10 V	-10 V	-10 V	-10 V	4.0 V	IN4A									"	
	"	17	0.8 V						-10 V	-10 V	-10 V	-10 V	-10 V	-10 V	-10 V	-10 V	-10 V	10 V	0.8 V	IN1B									"	
	"	18	4.0 V														10 V	-10 V	0.8 V	IN2B									"	
	"	19	0.8 V															10 V	-10 V	4.0 V	IN3B								"	
	"	20	4.0 V															10 V	-10 V	4.0 V	IN4B								"	
	"	21	0.8 V					10 V	10 V	10 V	10 V	10 V	10 V	10 V	10 V	10 V	10 V	10 V	0.8 V	IN1A									"	
	"	22	4.0 V				10 V	-10 V	10 V	10 V	10 V	10 V	10 V	10 V	10 V	10 V	10 V	10 V	0.8 V	IN2A									"	
	"	23	0.8 V					10 V	-10 V	10 V	10 V	10 V	10 V	10 V	10 V	10 V	10 V	10 V	4.0 V	IN3A									"	
	"	24	4.0 V						10 V	-10 V	-10 V	-10 V	-10 V	-10 V	-10 V	-10 V	-10 V	-10 V	4.0 V	IN4A									"	
	"	25	0.8 V						10 V									-10 V	0.8 V	IN1B									"	
	"	26	4.0 V															-10 V	10 V	0.8 V	IN2B								"	
	"	27	0.8 V															-10 V	10 V	4.0 V	IN3B								"	
	"	28	4.0 V															-10 V	10 V	4.0 V	IN4B								"	
	I _{D(OFF)}	"	29	0.8 V			-10 V	-10 V	-10 V	-10 V	-10 V	-10 V	-10 V	-10 V	-10 V	-10 V	-10 V	-10 V	0.8 V	OUTA		-10	10	-125	125	-125	125	"		
"		30				-10 V	-10 V	-10 V	-10 V	-10 V	-10 V	-10 V	-10 V	-10 V	-10 V	-10 V	-10 V		OUTB									"		
"		31				10 V	10 V	10 V	10 V	10 V	10 V	10 V	10 V	10 V	10 V	10 V	10 V		OUTA									"		
"		32				10 V	10 V	10 V	10 V	10 V	10 V	10 V	10 V	10 V	10 V	10 V	10 V		OUTB									"		
I _{D(ON)}	"	33		4.0 V		10 V	-10 V	-10 V	-10 V	-10 V	-10 V	-10 V	-10 V	-10 V	-10 V	-10 V	-10 V		IN1A & OUTA									"		
	"	34	4.0 V			-10 V	10 V	-10 V	-10 V	-10 V	-10 V	-10 V	-10 V	-10 V	-10 V	-10 V	-10 V		IN2A & OUTA									"		
	"	35	0.8 V				-10 V	10 V	-10 V	-10 V	-10 V	-10 V	-10 V	-10 V	-10 V	-10 V	-10 V		4.0 V	IN3A & OUTA									"	
	"	36	4.0 V					-10 V	10 V	-10 V	-10 V	-10 V	-10 V	-10 V	-10 V	-10 V	-10 V		4.0 V	IN4A & OUTA									"	
	"	37	0.8 V						-10 V	-10 V	10 V								0.8 V	IN1B & OUTB									"	
	"	38	4.0 V															10 V	-10 V	0.8 V	IN2B & OUTB								"	
	"	39	0.8 V															10 V	-10 V	4.0 V	IN3B & OUTB								"	
	"	40	4.0 V															10 V	-10 V	-10 V	4.0 V	IN4B & OUTB								"
	"	41	0.8 V					10 V	10 V	10 V	10 V	10 V	10 V	10 V	10 V	10 V	10 V	10 V	0.8 V	IN1A & OUTA									"	
	"	42	4.0 V				10 V	-10 V	10 V	10 V	10 V	10 V	10 V	10 V	10 V	10 V	10 V	10 V	0.8 V	IN2A & OUTA									"	
	"	43	0.8 V					10 V	-10 V	10 V	10 V	10 V	10 V	10 V	10 V	10 V	10 V	10 V	4.0 V	IN3A & OUTA									"	
	"	44	4.0 V						10 V	-10 V	-10 V	-10 V	-10 V	-10 V	-10 V	-10 V	-10 V	-10 V	4.0 V	IN4A & OUTA									"	
	"	45	0.8 V						10 V	10 V	-10 V	-10 V	-10 V	-10 V	-10 V	-10 V	-10 V		0.8 V	IN1B & OUTB									"	
	"	46	4.0 V															-10 V	10 V	0.8 V	IN2B & OUTB								"	
	"	47	0.8 V															-10 V	10 V	4.0 V	IN3B & OUTB								"	
	"	48	4.0 V															-10 V	10 V	4.0 V	IN4B & OUTB								"	

See footnotes at end of table.

TABLE III. Group A inspection for device type 06 – Continued.

Symbol	MIL-STD-883 test method	Case E	Terminal conditions ^{1/}																Measured Terminal	Test limits						Unit	
			1	2	3	4	5	6	7	8	9	10	11	12	13	14	15	16		Subgroup 1 T _A = 25°C		Subgroup 2 T _A = 125°C		Subgroup 3 T _A = -55°C			
			Test no.	A0	EN	V-	IN1A	IN2A	IN3A	IN4A	OUTA	OUTB	IN4B	IN3B	IN2B	IN1B	V+	GND		A1	Min	Max	Min	Max	Min		Max
I+		49	0 V	5.0 V	-15 V											15 V	GND	0 V	V+		2.0		2.0		2.0	mA	
I-		50	"	5.0 V	"											"	"	"	V-		-1		-1		-1	"	
I+SBY		51	"	0 V	"											"	"	"	V+		2.0		2.0		2.0	"	
I-SBY		52	"	"	"											"	"	"	V-		-1.0		-1.0		-1.0	"	
I _{D+(OFF)} over-voltage		53	0.8 V	0.8 V	"	33 V				0 V						"	"	0.8 V	OUTA		-2.0	2.0	-2.0	2.0	-2.0	2.0	μA
		54	4.0 V	"	"		33 V									"	"	"	"		"	"	"	"	"	"	"
		55	0.8 V	"	"			33 V								"	"	4.0 V	"		"	"	"	"	"	"	"
		56	4.0 V	"	"				33 V							"	"	4.0 V	"		"	"	"	"	"	"	"
		57	0.8 V	"	"					0 V				33 V	33 V	"	"	0.8 V	OUTB		"	"	"	"	"	"	"
		58	4.0 V	"	"								33 V			"	"	0.8 V	"		"	"	"	"	"	"	"
		59	0.8 V	"	"									33 V		"	"	4.0 V	"		"	"	"	"	"	"	"
		60	4.0 V	"	"								33 V			"	"	4.0 V	"		"	"	"	"	"	"	"
I _{D-(OFF)} over-voltage		61	0.8 V	"	"	-33 V				0 V					"	"	0.8 V	OUTA		"	"	"	"	"	"	"	
		62	4.0 V	"	"		-33 V								"	"	0.8 V	"		"	"	"	"	"	"	"	
		63	0.8 V	"	"			-33 V							"	"	4.0 V	"		"	"	"	"	"	"	"	"
		64	4.0 V	"	"				-33 V						"	"	4.0 V	"		"	"	"	"	"	"	"	"
		65	0.8 V	"	"					0 V					-33 V	"	"	0.8 V	OUTB		"	"	"	"	"	"	"
		66	4.0 V	"	"									-33 V	"	"	0.8 V	"		"	"	"	"	"	"	"	"
		67	0.8 V	"	"										-33 V	"	"	4.0 V	"		"	"	"	"	"	"	"
		68	4.0 V	"	"											-33 V	"	4.0 V	"		"	"	"	"	"	"	"
R _{DS1}		69	0.8 V	4.0 V	"	10 V					100 μA				"	"	0.8 V	IN1A & OUTA		1.5		1.8		1.5	kΩ		
		70	4.0 V	"	"		10 V								"	"	0.8 V	IN2A & OUTA		"	"	"	"	"	"		
		71	0.8 V	"	"			10 V							"	"	4.0 V	IN3A & OUTA		"	"	"	"	"	"	"	
		72	4.0 V	"	"				10 V						"	"	4.0 V	IN4A & OUTA		"	"	"	"	"	"	"	
		73	0.8 V	"	"						100 μA				10 V	"	"	0.8 V	IN1B & OUTB		"	"	"	"	"	"	
		74	4.0 V	"	"									10 V	"	"	0.8 V	IN2B & OUTB		"	"	"	"	"	"	"	
		75	0.8 V	"	"										10 V	"	"	4.0 V	IN3B & OUTB		"	"	"	"	"	"	"
		76	4.0 V	"	"									10 V	"	"	4.0 V	IN4B & OUTB		"	"	"	"	"	"	"	
		77	0.8 V	"	"	-10 V										"	"	0.8 V	IN1A & OUTA		"	"	"	"	"	"	"
		78	4.0 V	"	"		-10 V									"	"	0.8 V	IN2A & OUTA		"	"	"	"	"	"	"
		79	0.8 V	"	"			-10 V								"	"	4.0 V	IN3A & OUTA		"	"	"	"	"	"	"
		80	4.0 V	"	"				-10 V							"	"	4.0 V	IN4A & OUTA		"	"	"	"	"	"	"
		81	0.8 V	"	"										-100 μA	"	"	0.8 V	IN1B & OUTB		"	"	"	"	"	"	"
		82	4.0 V	"	"											-10 V	"	0.8 V	IN2B & OUTB		"	"	"	"	"	"	"
		83	0.8 V	"	"												-10 V	4.0 V	IN3B & OUTB		"	"	"	"	"	"	"
		84	4.0 V	"	"													4.0 V	IN4B & OUTB		"	"	"	"	"	"	"
R _{DS2}		85 thru 100 – Same terminal conditions as for tests 69 thru 84, except V _t = ±10 V, V _S = ±7.5 V and limits as shown.																	2.2		2.2		2.2	"			

See footnotes at end of table.

TABLE III. Group A inspection for device type 06 – Continued.

Symbol	MIL-STD-883 test method	Case E	Terminal conditions 1/														Measured Terminal	Test limits						Unit		
			1	2	3	4	5	6	7	8	9	10	11	12	13	14		15	16	Subgroup 4 T _A = 25°C						
			Test no.	A0	EN	V-	IN1A	IN2A	IN3A	IN4A	OUTA	OUTB	IN4B	IN3B	IN2B	IN1B		V+	GND	A1	Min	Max				
C _A	3012	101	4/		GND										GND	GND	A0	10					pF			
		102														A1	10									
C _{OS}		103	0 V	0 V						5/						0 V	0 V	OUTA	25							
		104									5/							OUTB	25							
C _{IS}		105				4/												IN1A	10							
		106					4/											IN2A								
		107						4/										IN3A								
		108							4/									IN4A								
		109								4/				4/				IN1B								
		110											4/					IN2B								
		111												4/				IN3B								
		112													4/			IN4B								
C _{EN}		113		4/												GND	EN									
																		Subgroup 9 T _A = 25°C		Subgroup 10 T _A = 125°C		Subgroup 11 T _A = -55°C				
																		Min	Max	Min	Max	Min	Max			
t _{ON(A)} and t _{OFF(A)}	3003 fig. 12	114		5 V	-15 V	GND	GND	GND	10 V	OUT		GND	GND	GND	GND	15 V	GND	ADDRESS IN		1,000				ns		
		115							-10 V									TO OUTA								
		116							10 V																	
		117							-10 V																	
		118					10 V			GND																
		119					-10 V																			
		120					10 V																			
		121					-10 V																			
		122					GND				OUT	10 V							ADDRESS IN							
		123										-10 V							TO OUTB							
		124										10 V														
		125										-10 V														
		t _{ON(EN)} and t _{OFF(EN)}	3003 fig. 13	130	GND			10 V	10 V	10 V	10 V	OUT		GND			GND			ENABLE						
131						-10 V	-10 V	-10 V	-10 V									TO OUTA								
132						10 V	10 V	10 V	10 V																	
133						-10 V	-10 V	-10 V	-10 V																	
134						GND	GND	GND	GND		OUT	10 V	10 V	10 V	10 V				ENABLE							
135												-10 V	-10 V	-10 V	-10 V				TO OUTB							
136												10 V	10 V	10 V	10 V											
137										-10 V	-10 V	-10 V	-10 V													

See footnotes at end of table.

TABLE III. Group A inspection for device type 06 – Continued.

Symbol	MIL-STD-883 test method	Case E	Terminal conditions 1/																Measured Terminal	Test limits				Unit			
			1	2	3	4	5	6	7	8	9	10	11	12	13	14	15	16		Subgroup 12 T _A = 25°C							
			Test no.	A0	EN	V-	IN1A	IN2A	IN3A	IN4A	OUTA	OUTB	IN4B	IN3B	IN2B	IN1B	V+	GND		A1	Min	Max					
V _{ISO}	fig. 15	138	GND	0 V	-15 V	IN	IN	IN	IN	OUT		IN	IN	IN	IN	15 V	GND	GND	OUTA	50							dB
	fig. 15	139	"	0 V	"	"	"	"	"	"	OUT	"	"	"	"	"	"	"	OUTB	"							"
V _{CT}	fig. 16	140	"	5 V	"	6/	"	"	"	"	OUT	"	"	"	"	"	"	"	OUTA	"							"
	fig. 16	141	"	5 V	"	6/	"	"	"	"	OUT	"	"	"	"	"	"	"	OUTB	"							"
V _{CTE}	fig. 17	142	IN	"	"	GND				OUT						"	IN	OUTA	"	10						mV	
	fig. 17	143	IN	"	"	GND					OUT					"	IN	OUTB	"	10							mV
																				Subgroup 13 T _A = 25°C							
																				Min	Max						
t _D	fig. 14	144		5 V	-15 V	10 V	10 V	10 V	10 V	OUT		GND	GND	GND	GND	15 V	GND		OUTA	5						ns	
	"	145		"	"	-10 V	-10 V	-10 V	-10 V	"		"	"	"	"	"	"	"	"	"	"						"
	"	146		"	"	10 V	10 V	10 V	10 V	"		"	"	"	"	"	"	"	"	"	"	"					"
	"	147		"	"	-10 V	-10 V	-10 V	-10 V	"		"	"	"	"	"	"	"	"	"	"	"					"
	"	148		"	"	GND	GND	GND	GND		OUT	10 V	10 V	10 V	10 V	"	"	"	"	OUTB	"						"
	"	149		"	"	"	"	"	"	"		"	-10 V	-10 V	-10 V	-10 V	"	"	"	"	"	"					"
	"	150		"	"	"	"	"	"	"		"	10 V	10 V	10 V	10 V	"	"	"	"	"	"					"
	"	151		"	"	"	"	"	"	"		"	-10 V	-10 V	-10 V	-10 V	"	"	"	"	"	"					"

See footnotes at end of table.

TABLE III. Group A inspection for device type 07.

Symbol	MIL-STD-883 test method	Case E	Terminal conditions 1/																Measured Terminal	Test limits						Unit	
			1	2	3	4	5	6	7	8	9	10	11	12	13	14	15	16		Subgroup 1 T _A = 25°C		Subgroup 2 T _A = 125°C		Subgroup 3 T _A = -55°C			
			Test no.	A0	EN	V-	IN1	IN2	IN3	IN4	OUT	IN8	IN7	IN6	IN5	V+	GND	A2		A1	Min	Max	Min	Max	Min		Max
I _{IH} 2/	3010	1	GND	5.0 V	-15 V										15 V	GND	2.4 V	GND	A2	-0.1	1.0	-0.1	1.0	-0.1	1.0	μA	
		2	GND	5.0 V													GND	2.4 V	A1								
		3	2.4 V	5.0 V													GND	GND	A0								
		4	GND	4.5 V													GND	GND	EN								
I _{IL} 2/	3009	5	5.0 V	5.0 V												0.8 V	5 V	A2	-1.0	0.1	-1.0	0.1	-1.0	0.1			
		6	5.0 V													5 V	0.8 V	A1									
		7	0.8 V													5 V	5 V	A0									
		8	5.0 V	0.8 V												5 V	5 V	EN									
I _{S(OFF)} 3/		9	0.8 V			10 V	-10 V	-10 V	-10 V	-10 V	-10 V	-10 V	-10 V			0.8 V	0.8 V	IN1	-1	1	-50	50	-50	50	nA		
		10	2.4 V			-10 V	10 V	-10 V	-10 V								-10 V	IN2									
		11	0.8 V				-10 V	10 V	-10 V									2.4 V	IN3								
		12	2.4 V					-10 V	10 V									2.4 V	IN4								
		13	0.8 V							-10 V							2.4 V	0.8 V	IN5								
		14	2.4 V											10 V	-10 V			0.8 V	IN6								
		15	0.8 V											10 V	-10 V	-10 V		2.4 V	IN7								
		16	2.4 V									10 V	-10 V	-10 V	-10 V			2.4 V	IN8								
		17	0.8 V				10 V	10 V	10 V	10 V							0.8 V	0.8 V	IN1								
		18	2.4 V				10 V	-10 V	10 V	10 V								0.8 V	IN2								
		19	0.8 V				10 V	-10 V	10 V	10 V								2.4 V	IN3								
		20	2.4 V					10 V	-10 V	10 V								2.4 V	IN4								
		21	0.8 V							10 V						-10 V		2.4 V	0.8 V	IN5							
		22	2.4 V												-10 V	10 V		0.8 V	IN6								
		23	0.8 V												-10 V	10 V	10 V		2.4 V	IN7							
		24	2.4 V									-10 V	10 V	10 V	10 V			2.4 V	IN8								
I _{D(OFF)}		25	0.8 V			-10 V	-10 V	-10 V	-10 V	10 V	-10 V	-10 V	-10 V	-10 V		0.8 V	0.8 V	OUT	-10	10	-250	250	-250	250			
26		0.8 V				10 V	10 V	10 V	10 V	-10 V	10 V	10 V	10 V	10 V				OUT									
I _{D(ON)}		27	0.8 V	4.0 V		10 V	-10 V	-10 V	-10 V	10 V	-10 V	-10 V	-10 V					IN1 & OUT									
		28	2.4 V			-10 V	10 V	-10 V	-10 V										IN2 & OUT								
		29	0.8 V				-10 V	10 V	-10 V									2.4 V	IN3 & OUT								
		30	2.4 V					-10 V	10 V									2.4 V	IN4 & OUT								
		31	0.8 V							-10 V						10 V		0.8 V	IN5 & OUT								
		32	2.4 V												10 V	-10 V		0.8 V	IN6 & OUT								
		33	0.8 V												10 V	-10 V	-10 V	2.4 V	IN7 & OUT								
		34	2.4 V									10 V	-10 V	-10 V	-10 V			2.4 V	IN8 & OUT								
		35	0.8 V					10 V	10 V	10 V	10 V	-10 V					0.8 V	0.8 V	IN1 & OUT								
		36	2.4 V				10 V	-10 V	10 V	10 V								0.8 V	IN2 & OUT								
		37	0.8 V					10 V	-10 V	10 V								2.4 V	IN3 & OUT								
		38	2.4 V						10 V	-10 V								2.4 V	IN4 & OUT								
		39	0.8 V							10 V						-10 V		2.4 V	0.8 V	IN5 & OUT							
		40	2.4 V												-10 V	10 V		0.8 V	IN6 & OUT								
		41	0.8 V												-10 V	10 V	10 V	2.4 V	IN7 & OUT								
		42	2.4 V									-10 V	10 V	10 V	10 V			2.4 V	IN8 & OUT								

See footnotes at end of table.

TABLE III. Group A inspection for device type 07 – Continued.

Symbol	MIL-STD-883 test method	Case E	Terminal conditions 1/																Measured Terminal	Test limits						Unit				
			1	2	3	4	5	6	7	8	9	10	11	12	13	14	15	16		Subgroup 1 T _A = 25°C		Subgroup 2 T _A = 125°C		Subgroup 3 T _A = -55°C						
			Test no.	A0	EN	V-	IN1	IN2	IN3	IN4	OUT	IN8	IN7	IN6	IN5	V+	GND	A2		A1	Min	Max								
I+		43	0 V	5.0 V	-15 V													15 V	GND	0 V	0 V	V+		12		12		12	mA	
I-		44	"	5.0 V	"													"	"	"	"	V-		-12		-12		-12	"	
I+SBY		45	"	0 V	"													"	"	"	"	V+		3.5		3.5		3.5	"	
I-SBY		46	"	0 V	"													"	"	"	"	V-		-3.5		-3.5		-3.5	"	
R _{DS1}		47	0.8 V	4.5 V	"	10 V											1 mA	"	"	0.8 V	0.8 V	IN1 & OUT		400		500		400	Ω	
		48	2.4 V	"	"		10 V										"	"	"	"	"	IN2 & OUT		"		"		"	"	
		49	0.8 V	"	"				10 V								"	"	"	"	2.4 V	"	IN3 & OUT		"		"		"	"
		50	2.4 V	"	"					10 V							"	"	"	"	2.4 V	"	IN4 & OUT		"		"		"	"
		51	0.8 V	"	"									10 V			"	"	"	2.4 V	0.8 V	IN5 & OUT		"		"		"	"	
		52	2.4 V	"	"										10 V		"	"	"	0.8 V	0.8 V	IN6 & OUT		"		"		"	"	
		53	0.8 V	"	"											10 V	"	"	"	2.4 V	"	IN7 & OUT		"		"		"	"	
		54	2.4 V	"	"												"	"	"	2.4 V	"	IN8 & OUT		"		"		"	"	
		55	0.8 V	"	"		-10 V										"	"	"	0.8 V	0.8 V	IN1 & OUT		"		"		"	"	
		56	2.4 V	"	"			-10 V									"	"	"	"	0.8 V	"	IN2 & OUT		"		"		"	"
		57	0.8 V	"	"				-10 V								"	"	"	2.4 V	"	IN3 & OUT		"		"		"	"	
		58	2.4 V	"	"					-10 V							"	"	"	"	2.4 V	"	IN4 & OUT		"		"		"	"
		59	0.8 V	"	"											-10 V	"	"	"	2.4 V	0.8 V	IN5 & OUT		"		"		"	"	
		60	2.4 V	"	"												"	"	"	0.8 V	"	IN6 & OUT		"		"		"	"	
	61	0.8 V	"	"												"	"	"	2.4 V	"	IN7 & OUT		"		"		"	"		
	62	2.4 V	"	"											-10 V	"	"	"	2.4 V	"	IN8 & OUT		"		"		"	"		
R _{DS2}		63 thru 78	Same terminal conditions as tests 47 thru 62, except V _± = ±10 V, V _S = +7.5 V and limits as shown.																	1,000		1,000		1,000	"					
R _{DS2}		79 thru 94	Same terminal conditions as tests 47 thru 62, except V _± = ±10 V, V _S = -7.5 V and limits as shown.																	1,000		1,000		1,000	"					
																	Subgroup 4 T _A = 25°C													
																	Min	Max												
C _A	3012	95			GND														GND	GND	4/		A2		10				pF	
	"	96			"														"	"		4/	A1		10				"	
	"	97	4/		"														"	"			A0		10				"	
C _{OS}	"	98	0 V		"													"	"	0 V	0 V	OUT		45				"		
C _{IS}	"	99	"	0 V	"	4/												"	"	"	"	IN1		10				"		
	"	100	"	"	"		4/											"	"	"	"	IN2		"				"		
	"	101	"	"	"			4/										"	"	"	"	IN3		"				"		
	"	102	"	"	"				4/									"	"	"	"	IN4		"				"		
	"	103	"	"	"												"	"	"	"	"	IN5		"				"		
	"	104	"	"	"												"	"	"	"	"	IN6		"				"		
	"	105	"	"	"												"	"	"	"	"	IN7		"				"		
	"	106	"	"	"												"	"	"	"	"	IN8		"				"		
C _{EN}	"	107	"	4/	"											"	"	"	"	"	EN		"					"		

See footnotes at end of table.

TABLE III. Group A inspection for device type 07 – Continued.

Symbol	MIL-STD-883 test method	Case E	Terminal conditions 1/																Measured Terminal	Test limits						Unit			
			1	2	3	4	5	6	7	8	9	10	11	12	13	14	15	16		Subgroup 9 T _A = 25°C		Subgroup 10 T _A = 125°C		Subgroup 11 T _A = -55°C					
			Test no.	A0	EN	V-	IN1	IN2	IN3	IN4	OUT	IN8	IN7	IN6	IN5	V+	GND	A2		A1	Min	Max	Min	Max	Min		Max		
t _{ON(A)} and t _{OFF(A)}	3003	108		5 V	-15 V	GND	GND	GND	GND	GND	OUT	10 V	GND	GND	GND	15 V	GND			OUT		1,000		1,500		1,000	ns		
	fig. 10	109		"	"	"	"	"	"	"	"	-10 V	"	"	"	"	"	"			"	"	"	"	"	"	"		
	"	110		"	"	"	"	"	"	"	"	10 V	"	"	"	"	"	"	"			"	"	"	"	"	"	"	
	"	111		"	"	"	"	"	"	"	"	-10 V	"	"	"	"	"	"	"			"	"	"	"	"	"	"	
	"	112		"	"	"	10 V	"	"	"	"	"	GND	"	"	"	"	"	"			"	"	"	"	"	"	"	
	"	113		"	"	"	-10 V	"	"	"	"	"	"	"	"	"	"	"	"			"	"	"	"	"	"	"	"
	"	114		"	"	"	10 V	"	"	"	"	"	"	"	"	"	"	"	"			"	"	"	"	"	"	"	"
"	115		"	"	"	-10 V	"	"	"	"	"	"	"	"	"	"	"	"			"	"	"	"	"	"	"	"	"
t _{ON(EN)} and t _{OFF(EN)}	3003	116	GND		"	10 V	10 V	10 V	10 V	"	10 V	10 V	10 V	10 V	"	"	GND	GND	"	"	"	"	"	"	"	"	"		
	fig. 11	117	"		"	-10 V	-10 V	-10 V	-10 V	"	-10 V	-10 V	-10 V	-10 V	"	"	"	"	"	"	"	"	"	"	"	"	"		
	"	118	"		"	10 V	10 V	10 V	10 V	"	10 V	10 V	10 V	10 V	"	"	"	"	"	"	"	"	"	"	"	"	"		
	"	119	"		"	-10 V	-10 V	-10 V	-10 V	"	-10 V	-10 V	-10 V	-10 V	"	"	"	"	"	"	"	"	"	"	"	"	"	"	
																					Subgroup 12 T _A = 25°C								
																					Min	Max							
V _{ISO}	fig. 15	120	GND	0 V	-15 V	IN	IN	IN	IN	OUT	IN	IN	IN	IN	15 V	GND	GND	GND	OUT	50							dB		
V _{CT}	fig. 16	121	GND	5 V	-15 V	6/	IN	IN	IN	OUT	IN	IN	IN	IN	15 V	GND	GND	GND	OUT	50							dB		
V _{CTE}	fig. 17	122	IN	5 V	-15 V	GND				OUT				15 V	GND	IN	IN	OUT		10							mV		
																					Subgroup 13 T _A = 25°C								
																					Min	Max							
t _D	fig. 14	123		5 V	-15 V	10 V	10 V	10 V	10 V	OUT	10 V	10 V	10 V	10 V	15 V	GND			OUT	5							ns		
	"	124		"	"	-10 V	-10 V	-10 V	-10 V	"	-10 V	-10 V	-10 V	-10 V	"	"	"	"	"	"	"	"	"	"	"	"	"	"	
	"	125		"	"	10 V	10 V	10 V	10 V	"	10 V	10 V	10 V	10 V	"	"	"	"	"	"	"	"	"	"	"	"	"	"	
	"	126		"	"	-10 V	-10 V	-10 V	-10 V	"	-10 V	-10 V	-10 V	-10 V	"	"	"	"	"	"	"	"	"	"	"	"	"	"	

See footnotes at end of table.

TABLE III. Group A inspection for device type 08.

Symbol	MIL-STD-883 test method	Case E	Terminal conditions 1/																Measured Terminal	Test limits						Unit
			1	2	3	4	5	6	7	8	9	10	11	12	13	14	15	16		Subgroup 1 T _A = 25°C		Subgroup 2 T _A = 125°C		Subgroup 3 T _A = -55°C		
			Test no.	A0	EN	V-	IN1A	IN2A	IN3A	IN4A	OUTA	OUTB	IN4B	IN3B	IN2B	IN1B	V+	GND		A1	Min	Max	Min	Max	Min	
I _{IH} 2/	3010	1	GND	GND	-15 V											15 V	GND	2.4 V	A1	-0.1	1.0	-0.1	1.0	-0.1	1.0	μA
		2	2.4 V	GND														GND	A0							
		3	GND	4.5 V														GND	EN							
I _{IL} 2/	3009	4	5 V	5 V														0.8 V	A1	-1.0	0.1	-1.0	0.1	-1.0	0.1	
		5	0.8 V	5 V														5 V	A0							
		6	5.0 V	0.8 V														5 V	EN							
I _{S(OFF)} 3/		7	0.8 V			10 V	-10 V	-10 V	-10 V	-10 V	-10 V	-10 V	-10 V	-10 V				0.8 V	IN1A	-1	1	-50	50	-50	50	nA
		8	2.4 V			-10 V	10 V	-10 V	-10 V									0.8 V	IN2A							
		9	0.8 V				-10 V	10 V	-10 V									2.4 V	IN3A							
		10	2.4 V					-10 V	10 V									2.4 V	IN4A							
		11	0.8 V							-10 V						10 V		0.8 V	IN1B							
		12	2.4 V												10 V	-10 V		0.8 V	IN2B							
		13	0.8 V												10 V	-10 V		2.4 V	IN3B							
		14	2.4 V												10 V	-10 V	-10 V	-10 V	IN4B							
		15	0.8 V					10 V	10 V	10 V	10 V	10 V	10 V	10 V	10 V	10 V	10 V	0.8 V	IN1A							
		16	2.4 V				10 V	-10 V	10 V	10 V								0.8 V	IN2A							
		17	0.8 V					10 V	-10 V	10 V	10 V							2.4 V	IN3A							
		18	2.4 V						10 V	-10 V								2.4 V	IN4A							
		19	0.8 V							10 V						-10 V		0.8 V	IN1B							
		20	2.4 V													-10 V	10 V	0.8 V	IN2B							
		21	0.8 V														-10 V	10 V	IN3B							
22	2.4 V															2.4 V	IN4B									
I _{D(OFF)}		23	0.8 V			-10 V	-10 V	-10 V	-10 V	10 V	-10 V	-10 V	-10 V	-10 V	-10 V		0.8 V	OUTA	-10	10	-125	125	-125	125		
		24				-10 V	-10 V	-10 V	-10 V	-10 V	10 V	-10 V	-10 V	-10 V	-10 V			OUTB								
		25				10 V	10 V	10 V	10 V	-10 V	10 V	10 V	10 V	10 V	10 V			OUTA								
		26				10 V	10 V	10 V	10 V	10 V	-10 V	10 V	10 V	10 V	10 V			OUTB								
I _{D(ON)}		27		4.0 V		10 V	-10 V	-10 V	-10 V	-10 V								IN1A & OUTA								
		28	2.4 V			-10 V	10 V	-10 V	-10 V										IN2A & OUTA							
		29	0.8 V				-10 V	10 V	-10 V									2.4 V	IN3A & OUTA							
		30	2.4 V					-10 V	10 V									2.4 V	IN4A & OUTA							
		31	0.8 V						-10 V	-10 V	10 V					10 V		0.8 V	IN1B & OUTB							
		32	2.4 V												10 V	-10 V		0.8 V	IN2B & OUTB							
		33	0.8 V												10 V	-10 V	-10 V	2.4 V	IN3B & OUTB							
		34	2.4 V												10 V	-10 V	-10 V	2.4 V	IN4B & OUTB							
		35	0.8 V					10 V	10 V	10 V	10 V				10 V	10 V	10 V	0.8 V	IN1A & OUTA							
		36	2.4 V				10 V	-10 V	10 V	10 V								0.8 V	IN2A & OUTA							
		37	0.8 V					10 V	-10 V	10 V								2.4 V	IN3A & OUTA							
		38	2.4 V						10 V	-10 V								2.4 V	IN4A & OUTA							
		39	0.8 V							10 V	10 V	-10 V						0.8 V	IN1B & OUTB							
		40	2.4 V													-10 V	10 V	0.8 V	IN2B & OUTB							
		41	0.8 V														-10 V	10 V	IN3B & OUTB							
		42	2.4 V															2.4 V	IN4B & OUTB							

See footnotes at end of table.

TABLE III. Group A inspection for device type 08 – Continued.

Symbol	MIL-STD-883 test method	Case E	Terminal conditions 1/																Measured Terminal	Test limits						Unit		
			1	2	3	4	5	6	7	8	9	10	11	12	13	14	15	16		Subgroup 1 T _A = 25°C		Subgroup 2 T _A = 125°C		Subgroup 3 T _A = -55°C				
			Test no.	A0	EN	V-	IN1A	IN2A	IN3A	IN4A	OUTA	OUTB	IN4B	IN3B	IN2B	IN1B	V+	GND		A1	Min	Max						
I+		43	0 V	5.0 V	-15 V											15 V	GND	0 V	V+		12		12		12	mA		
I-		44	"	5.0 V	"											"	"	"	V-		-12		-12		-12	"		
I+SBY		45	"	0 V	"											"	"	"	V+		3.5		3.5		3.5	"		
I-SBY		46	"	0 V	"											"	"	"	V-		-3.5		-3.5		-3.5	"		
R _{DS1}		47	0.8 V	4.5 V	"	10 V					1 mA					"	"	0.8 V	IN1A & OUTA		400		500		400	Ω		
		48	2.4 V	"	"		10 V				"					"	"	0.8 V	IN2A & OUTA		"		"		"	"		
		49	0.8 V	"	"			10 V			"					"	"	2.4 V	IN3A & OUTA		"		"		"	"		
		50	2.4 V	"	"				10 V		"					"	"	2.4 V	IN4A & OUTA		"		"		"	"		
		51	0.8 V	"	"						"			1 mA		10 V	"	"	0.8 V	IN1B & OUTB		"		"		"	"	
		52	2.4 V	"	"						"					10 V	"	"	0.8 V	IN2B & OUTB		"		"		"	"	
		53	0.8 V	"	"						"						"	"	2.4 V	IN3B & OUTB		"		"		"	"	
		54	2.4 V	"	"						"					10 V	"	"	2.4 V	IN4B & OUTB		"		"		"	"	
		55	0.8 V	"	"		-10 V										"	"	0.8 V	IN1A & OUTA		"		"		"	"	
		56	2.4 V	"	"			-10 V									"	"	0.8 V	IN2A & OUTA		"		"		"	"	
		57	0.8 V	"	"				-10 V								"	"	2.4 V	IN3A & OUTA		"		"		"	"	
		58	2.4 V	"	"					-10 V							"	"	2.4 V	IN4A & OUTA		"		"		"	"	
		59	0.8 V	"	"									-1 mA			-10 V	"	"	0.8 V	IN1B & OUTB		"		"		"	"
		60	2.4 V	"	"												-10 V	"	"	0.8 V	IN2B & OUTB		"		"		"	"
	61	0.8 V	"	"													"	"	2.4 V	IN3B & OUTB		"		"		"	"	
	62	2.4 V	"	"												-10 V	"	"	2.4 V	IN4B & OUTB		"		"		"	"	
R _{DS2}	63 thru 78 – Same terminal conditions as tests 47 thru 62, except V _± = ±10 V, V _S = ±7.5 V and limits as shown.																				1,000		1,000		1,000	"		
																			Subgroup 4 T _A = 25°C									
																			Min	Max								
C _A	3012	79	4/		GND										GND	GND		A0		10					pF			
C _{OS}	"	80													"	"	4/	A1		10					"			
	"	81	0 V	0 V	"						5/				"	"		OUTA		25						"		
C _{IS}	"	82	"	"	"													OUTB		25					"			
	"	83	"	"	"	4/											0 V	IN1A		10					"			
	"	84	"	"	"		4/										"	IN2A		"					"			
	"	85	"	"	"			4/									"	IN3A		"					"			
	"	86	"	"	"					4/							"	IN4A		"					"			
	"	87	"	"	"												4/	IN1B		"					"			
	"	88	"	"	"													4/	IN2B		"				"			
	"	89	"	"	"														IN3B		"				"			
C _{EN}	"	90	"	"	"						4/						"	IN4B		"					"			
	"	91		4/	"												"	EN		"					"			

See footnotes at end of table.

TABLE III. Group A inspection for device type 08 – Continued.

Symbol	MIL-STD-883 test method	Case E	Terminal conditions ^{1/}																Measured Terminal	Test limits						Unit			
			1	2	3	4	5	6	7	8	9	10	11	12	13	14	15	16		Subgroup 9 T _A = 25°C		Subgroup 10 T _A = 125°C		Subgroup 11 T _A = -55°C					
			Test no.	A0	EN	V-	IN1A	IN2A	IN3A	IN4A	OUTA	OUTB	IN4B	IN3B	IN2B	IN1B	V+	GND		A1	Min	Max	Min	Max	Min		Max		
t _{ON(A)} and t _{OFF(A)}	fig. 12	92		5 V	-15 V	GND	GND	GND	10 V	OUT		GND	GND	GND	GND	15 V	GND		ADDRESS IN TO OUTA		1,000		1,500		1,000	ns			
		93							-10 V																				
		94							10 V																				
		95							-10 V																				
		96					10 V			GND																			
		97					-10 V																						
		98					10 V																						
		99					-10 V																						
		100					GND				OUT	10 V									ADDRESS IN TO OUTB								
		101										-10 V																	
		102										10 V																	
		103										-10 V																	
		104										GND			10 V														
		105														-10 V													
106														10 V															
107														-10 V															
t _{ON(EN)} and t _{OFF(EN)}	fig. 13	108	GND			10 V	10 V	10 V	10 V	OUT					GND			GND	ENABLE TO OUTA										
		109				-10 V	-10 V	-10 V	-10 V																				
		110				10 V	10 V	10 V	10 V																				
		111				-10 V	-10 V	-10 V	-10 V																				
		112				GND	GND	GND	GND	OUT	10 V	10 V	10 V	10 V						ENABLE TO OUTB									
		113									-10 V	-10 V	-10 V	-10 V															
		114									10 V	10 V	10 V	10 V															
115									-10 V	-10 V	-10 V	-10 V																	
V _{ISO}	fig. 15	116	GND	0 V	-15 V	IN	IN	IN	IN	OUT		IN	IN	IN	IN	15 V	GND	GND	OUTA		Subgroup 12 T _A = 25°C								
		117		0 V						OUT										OUTB		Min	Max						
V _{CT}	fig. 16	118		5 V		6/				OUT					6/				OUTA										
		119				6/				OUT					6/					OUTB									
V _{CTE}	fig. 17	120	IN			GND				OUT					GND			IN	OUTA										
		121	IN			GND				OUT					GND			IN	OUTB										
t _D	fig. 14	122		5 V	-15 V	10 V	10 V	10 V	10 V	OUT		GND	GND	GND	GND	15 V	GND	IN	OUTA		Subgroup 13 T _A = 25°C								
		123				-10 V	-10 V	-10 V	-10 V													Min	Max						
		124				10 V	10 V	10 V	10 V																				
		125				-10 V	-10 V	-10 V	-10 V																				
		126				GND	GND	GND	GND	OUT	10 V	10 V	10 V	10 V						OUTB									
		127									-10 V	-10 V	-10 V	-10 V															
		128									10 V	10 V	10 V	10 V															
		129									-10 V	-10 V	-10 V	-10 V															

^{1/} Pins not designated may be high-level logic or open. Exceptions are as follows: V_{IC(POS)} tests, the V-, GND terminal shall be open; V_{IC(NEG)} tests, the V+ terminal shall be open.
^{2/} The device manufacturer may, at his option, measure I_{IL} and I_{IH} at 25°C for each individual input or measure all inputs together.
^{3/} The I_S and I_D measurements shall be performed in sequence.
^{4/} C_A, C_{EN}, and C_{IS} – Connect capacitance bridge between measured terminal and V_{SS}, frequency = 1 MHz, see 4.4.1c.
^{5/} C_{OS} – Connect capacitance bridge between measured output and V_{SS}, frequency = 1 MHz, see 4.4.1c.
^{6/} Connect input to ground through a 1 kΩ ±5% resistor.

4.4.1 Group A inspection. Group A inspection shall be in accordance with table III of MIL-PRF-38535 and as follows:

- a. Tests shall be as specified in table II herein.
- b. Subgroups 5, 6, 7, and 8 of method 5005 of MIL-STD-883 shall be omitted.
- c. Subgroup 4 (Ci measurements) shall be measured only for initial qualification and after process or design changes which may affect input capacitance. Capacitance shall be measured between the designated terminal and GND at a frequency of 1 MHz. Subgroup 4 shall be performed using a sample of 5 devices with no failures allowed.
- d. Subgroup 13 shall be added to group A inspection for all classes and it shall consist of the tests, conditions and limits as specified in table III. The sample size series shall be 10 for all classes (except on 0).
- e. Subgroup 12 shall be performed for initial qualification only using a sample of 5 devices for each device type submitted to group A inspections with no failures allowed. If not more than 1 failure is found in the first sample of 5, a second sample of 5 is permitted with no further failures allowed.

4.4.2 Group B inspection. Group B inspection shall be in accordance with table II of MIL-PRF-38535.

4.4.3 Group C inspection. Group C inspection shall be in accordance with table IV of MIL-PRF-38535 and as follows:

- a. End point electrical parameters shall be as specified in table II herein.
- b. The steady-state life test duration, test condition, and test temperature, or approved alternatives shall be as specified in the device manufacturer's QM plan in accordance with MIL-PRF-38535. The burn-in test circuit shall be maintained under document control by the device manufacturer's Technology Review Board (TRB) in accordance with MIL-PRF-38535 and shall be made available to the acquiring or preparing activity upon request. The test circuit shall specify the inputs, outputs, biases, and power dissipation, as applicable, in accordance with the intent specified in test method 1005 of MIL-STD-883.
- c. A special subgroup shall be added to the group C inspection requirements for class B devices, and shall consist of the tests, conditions, and limits as specified for subgroups 10 and 11 of group A.
- d. A special subgroup shall be added to group C inspection for class B devices only and it shall consist of group A, subgroup 12 as specified in table III herein. This special subgroup shall be performed on each device type that is qualified from those listed in 1.2.1 herein. After initial qualification, the special subgroup shall be performed periodically on a single device type selected from those device types previously qualified. A sample of 5 devices (of the device type to be inspected) shall be chosen and submitted to test with no failures allowed. If not more than 1 failure is found in the first sample of 5, a second sample of 5 is permitted with no further failures allowed. When more than one device type is qualified, the single device type selected shall be a different device for each subsequent periodic inspection until all qualified device types have been inspected. The sequence of single device types shall be repeated to fulfill the periodic inspection requirement.

4.4.4 Group D inspection. Group D inspection shall be in accordance with table V of MIL-PRF-38535.

- a. End point electrical parameters shall be as specified in table II herein.
- b. A special subgroup shall be added to group D inspection for class S devices only and it shall consist of group A, subgroups 4 and 7 as specified in table III herein. This special subgroup shall be performed on each device type that is qualified from those listed in 1.2.1 herein. After initial qualification, the special subgroup shall be performed periodically on a single device type selected from those device types previously qualified. When more than one device type is qualified, the single device type selected shall be a different device for each subsequent periodic inspection until all qualified device types have been inspected. The sequence of single device types shall be repeated to fulfill the periodic inspection requirement.

4.5 Methods of inspection. Methods of inspection shall be specified and as follows.

4.5.1 Voltage and current. All voltage values given are referenced to the microcircuit ground terminals. Currents given are conventional current and positive when flowing into the referenced terminal.

4.6 Data reporting. When specified in the acquisition document, a copy of the following data, as applicable, shall be applied:

- a. Attributes data for all screening tests (see 4.2) and variables data for all static burn-in, dynamic burn-in, and operating life tests.
- b. The technology conformance inspection data (see 4.4).

Table IV. Group C end-point electrical parameters. $T_A = 25^\circ\text{C}$

Parameter	Device types					
	01, 07	02	03, 08	04	05	06
R_{ON}	50 Ω or 10% <u>1/</u>	150 Ω or 10%	50 Ω or 10%	150 Ω or 10%	150 Ω or 10% <u>1/</u>	150 Ω or 10% <u>1/</u>
$I_{D(OFF)}$	15 nA	15 nA	15 nA	15 nA	15 nA	15 nA
$I_{S(OFF)}$	15 nA	15 nA	15 nA	15 nA	15 nA	15 nA

1/ Whichever is greater.

2/ Each of the above parameters shall be recorded before and after the required burn-in or life tests to determine deltas (Δ).

5. PACKAGING

5.1 Packaging requirements. For acquisition purposes, the packaging requirements shall be as specified in the contract or order (see 6.2). When packaging of materiel is to be performed by DoD personnel, these personnel need to contact the responsible packaging activity to ascertain requisite packaging requirements. Packaging requirements are maintained by the Inventory Control Point's packaging activity within the Military Department of Defense Agency, or within the Military Department's System Command. Packaging data retrieval is available from the managing Military Department's or Defense Agency's automated packaging files, CD-ROM products, or by contacting the responsible packaging activity.

6. NOTES

(This section contains information of a general or explanatory nature that may be helpful, but is not mandatory.)

6.1 Intended use. Microcircuits conforming to this specification are intended for logistic support of existing equipment.

6.2 Acquisition requirements. Acquisition documents should specify the following:

- a. Title, number, and date of the specification.
- b. PIN and compliance identifier, if applicable (see 1.2).
- c. Requirements for delivery of one copy of the conformance inspection data pertinent to the device inspection lot to be supplied with each shipment by the device manufacturer, if applicable.
- d. Requirements for certificate of compliance, if applicable.
- e. Requirements for notification of change of product or process to acquiring activity in addition to notification of the qualifying activity, if applicable.
- f. Requirements for failure analysis (including required test condition of MIL-STD-883, method 5003), corrective action and reporting of results, if applicable.
- g. Requirements for product assurance options.
- h. Requirements for special carriers, lead lengths, or lead forming, if applicable. These requirements should not affect the part number. Unless otherwise specified, these requirements will not apply to direct purchase by or direct shipment to the Government.
- i. Requirements for "JAN" marking.
- j. Packaging requirements (see 5.1).

MIL-M-38510/190D

6.3 Qualification. With respect to products requiring qualification, awards will be made only for products which are, at the time of award of contract, qualified for inclusion in Qualified Manufacturers List QML-38535 whether or not such products have actually been so listed by that date. The attention of the contractors is called to these requirements, and manufacturers are urged to arrange to have the products that they propose to offer to the Federal Government tested for qualification in order that they may be eligible to be awarded contracts or purchase orders for the products covered by this specification. Information pertaining to qualification of products may be obtained from DSCC-VQ, 3990 E. Broad Street, Columbus, Ohio 43123-1199.

6.4 Superseding information. The requirements of MIL-M-38510 have been superseded to take advantage of the available Qualified Manufacturer Listing (QML) system provided by MIL-PRF-38535. Previous references to MIL-M-38510 in this document have been replaced by appropriate references to MIL-PRF-38535. All technical requirements now consist of this specification and MIL-PRF-38535. The MIL-M-38510 specification sheet number and PIN have been retained to avoid adversely impacting existing government logistics systems and contractor's parts lists.

6.5 Abbreviations, symbols, and definitions. The abbreviations, symbols, and definitions used herein are defined in MIL-PRF-38535 and MIL-HDBK-1331 and as follows:

V_{IC}	Input clamp voltage.
I_{IL}	Low level (address) input current.
I_{IH}	High level (address) input current.
$I_{S(OFF)}$	Leakage current into the source terminal of an "OFF" switch.
$I_{D(OFF)}$	Leakage current into the drain terminal of an "OFF" switch.
$I_{D(ON)}$	Leakage current from an "ON" driver into the switch.
$I(+)$	Positive supply current.
$I(-)$	Negative supply current.
$I_{(SBY)}$	Standby supply current.
R_{ON}	Resistance of an "ON" switch.
C_A	Address capacitance.
C_{OS}	Output switch capacitance.
C_{IS}	Input switch capacitance.
C_{IOS}	Input to output (feedthrough) capacitance.
t_{PLH}	Propagation delay time: low to high level.
t_{PHL}	Propagation delay time: high to low level.
GND	Electrical ground.
V_{REF}	Reference voltage.
A	Address input to switch.
EN	Enable.
O/I	Output/Input.
I/O	Input/Output.

6.6 Logistic support. Lead materials and finishes (see 3.4) are interchangeable. Unless otherwise specified, microcircuits acquired for Government logistic support will be acquired to device class B (see 1.2.2), lead material and finish A (see 3.4). Longer length leads and lead forming should not affect the part number.

MIL-M-38510/190D

6.7 Substitutability. The cross-reference information below is presented for the convenience of users. Microcircuits covered by this specification will functionally replace the listed generic-industry type. Generic-industry microcircuit types may not have equivalent operational performance characteristics across military temperature ranges or reliability factors equivalent to MIL-M-38510 device types and may have slight physical variations in relation to case size. The presence of this information should not be deemed as permitting substitution of generic-industry types for MIL-M-38510 types or as a waiver of any of the provisions of MIL-PRF-38535.

<u>Military device type</u>	<u>Generic-industry type</u>
01	506, 6116
02	506A
03	507, 6216
04	507A
05	508A
06	509A
07	508, 6108
08	509, 6208

6.8 Changes from previous issue. Marginal notations are not used in this revision to identify changes with respect to the previous issue, due to the extensiveness of the changes.

Custodians:	Preparing activity:
Army – CR	DLA - CC
Navy - EC	
Air Force - 11	Project 5962-2125
NASA – NA	
DLA – CC	

Review activities:
 Army – MI, SM
 Navy – AS, CG, MC, SH, TD
 Air Force – 03, 19, 99

NOTE: The activities listed above were interested in this document as of the date of this document. Since organizations and responsibilities can change, you should verify the currency of the information above using the ASSIST Online database at <http://assist.daps.dla.mil> .